

C - PS



C - GGC



C - FSV

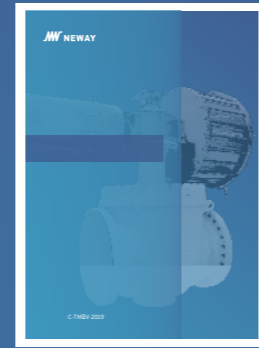

C - TMBV



C - FBV



C - CBV



C - MMBV



C - FWBV



C - BFV



C - DOV



C - TOV



C - CPS

: C - FSV - 2021



典型图号:



纽威阀门的图号包括了阀门的基本特征。当订购时，为了避免对您的需求的误解，请显示纽威阀门的图号。对于特殊订单，则还须提供详细的技术规格描述。

下面的描述对阀门的技术规格提供一个基本的向导：

①

② 阀门类型

			Y			Y
	G	GL	GLY	S	P	PY

③

	150	300	600	800	900	1500	2500
	1	3	6	8	9	15	25

④ 端部连接

				() / ()		RTJ
	S	N	B	SN	R	J

⑤

		RTJ			
	FW	J	FP	M	P

⑥

	C40	L70	H41	H42	H43	S40	S41	S42	S43
	A105N	A350 Gr.LF2	A350 Gr.LF2	A182 Gr.F22	A182 Gr.F5	A182 Gr.F304	A182 Gr.F316	A182 Gr.F304L	A182 Gr.F316L

⑦

No.1	13Cr	13Cr	ASTM A182-F6a
No.2	18Cr-8Ni	18Cr-8Ni	ASTM A182-F304
No.5	HarD faceD	HarD faceD	ASTM A182-F6a
No.8	13Cr	HarD faceD	ASTM A182-F6a
No.10	18Cr-8Ni-Mo	18Cr-8Ni-Mo	ASTM A182-F316
No.12	18Cr-8Ni-Mo	HarD faceD	ASTM A182-F316
No.15	18Cr-8Ni	HarD faceD	ASTM A182-F304
No.16	HarD faceD	HarD faceD	ASTM A182-F316

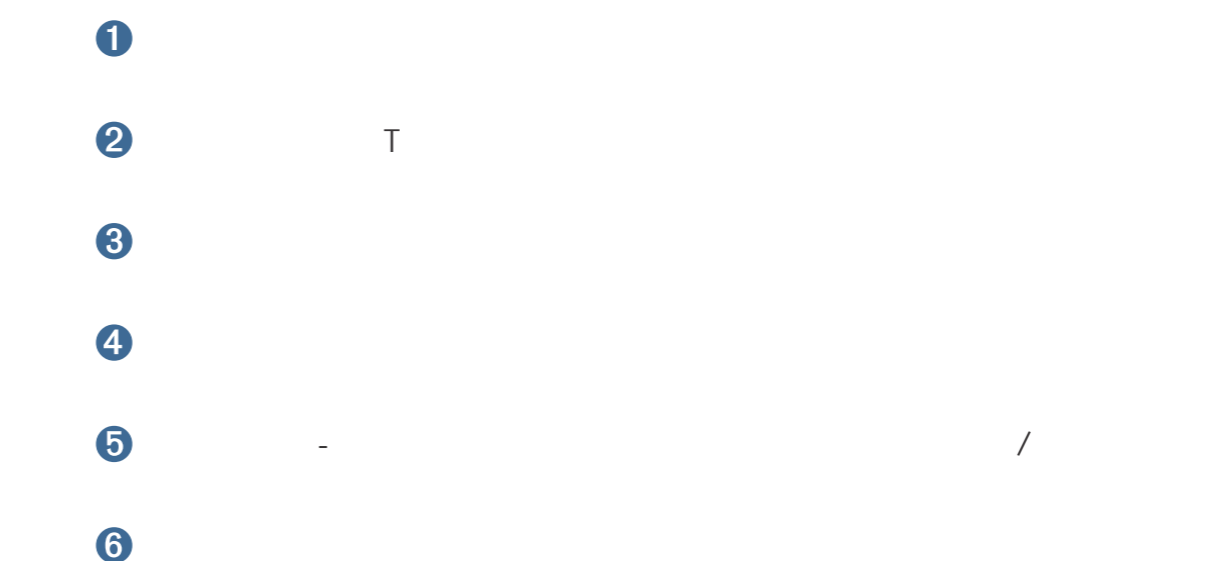
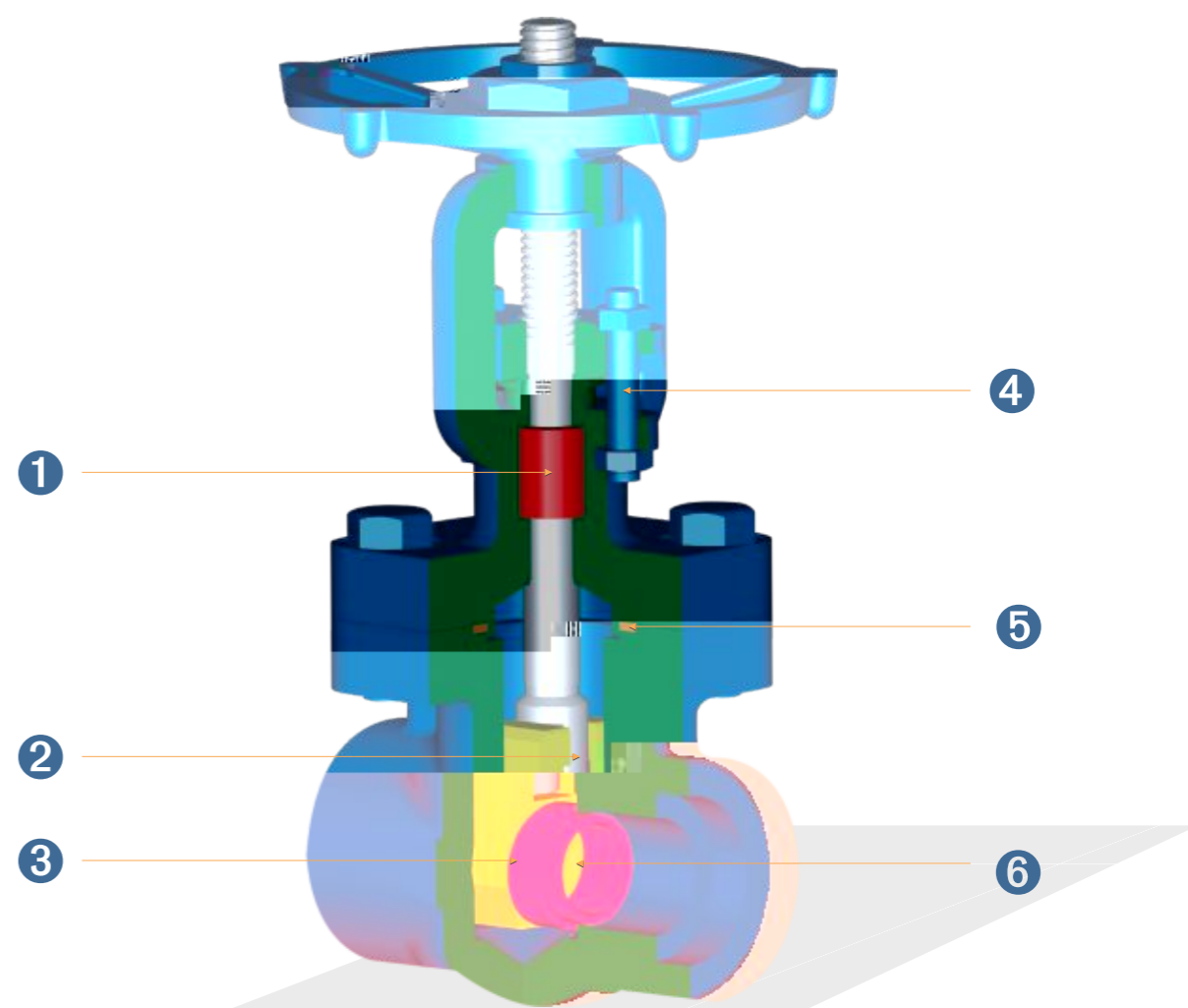

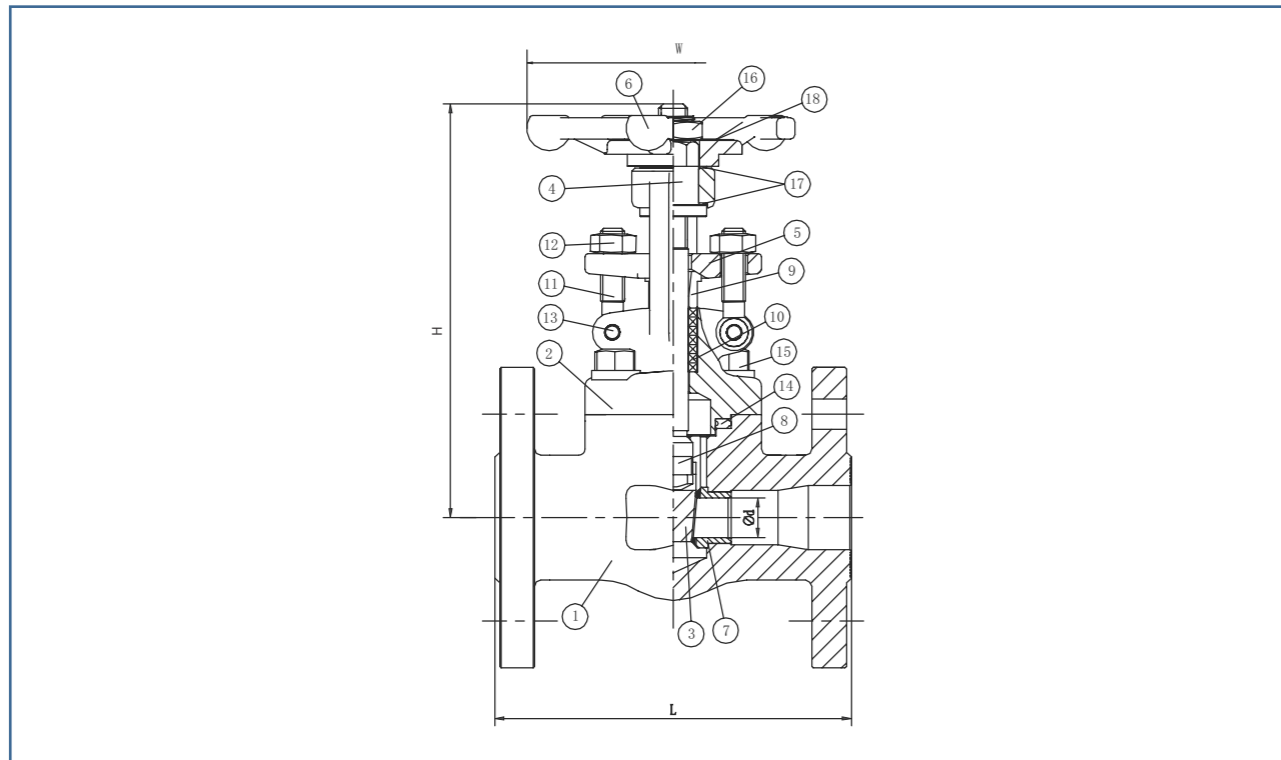
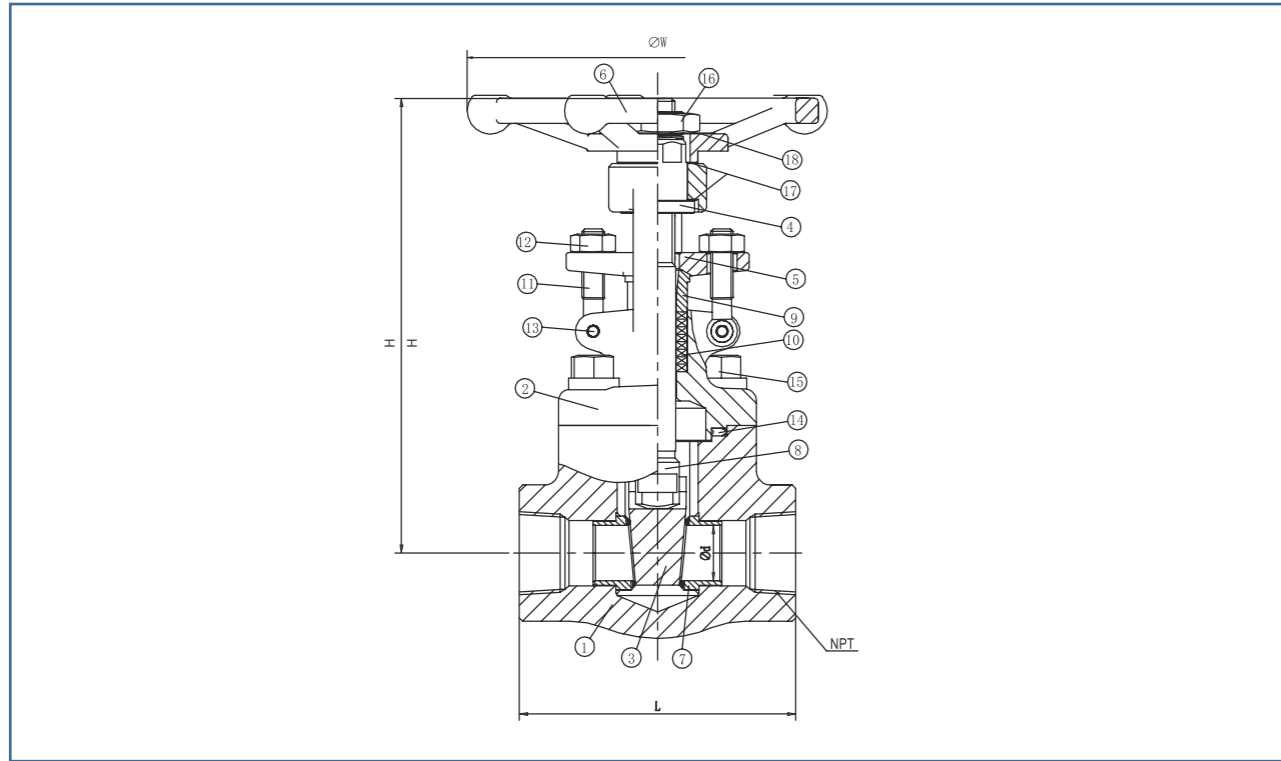

1	ASTM A105N	ASTM A182 F11/F22	ASTM A182 F304/F316
2	ASTM A105N	ASTM A182 F11/F22	ASTM A182 F304/F316
3	ASTM A276 410	ASTM A276 410	ASTM A182 F304/F316
4	ASTM A276 410	ASTM A276 410	ASTM A276 410
5	ASTM A105N	ASTM A105N	ASTM A182 F316
6	A197	A197	A197
7	ASTM A276 410/STL.6 OVERLAY	ASTM A276 410/STL.6 OVERLAY	ASTM A182 F304/F316/STL.6
8	ASTM A276 410	ASTM A276 410	ASTM A182 F304/F316
9	ASTM A276 420	ASTM A276 420	ASTM A276 316
10			
11	ASTM A193-B7	ASTM A193-B16	ASTM A193-B8
12	ASTM A194-2H	ASTM A194-7	ASTM A194-8
13	ASTM A276 304	ASTM A276 304	ASTM A276 316
14	/316LSS	/316LSS	/316LSS
15	ASTM A193-B7	ASTM A193-B16	ASTM A193-B8
16	AISI 1020	AISI 1020	AISI 1020
17	410	410	410
18	304SS	304SS	304SS

Class 800

-API 602

		1/4		3/8		1/2		3/4		1		1-1/4		1-1/2		2	
	L	mm	in	mm	in	mm	in	mm	in	mm	in	mm	in	mm	in	mm	in
	D	7.5	0.30	10	0.39	13	0.51	13	0.51	18	0.71	24	0.94	29	1.14	36.5	1.44
	H	157	6.18	157	6.18	157	6.18	157	6.18	185	7.28	226	8.90	241	9.49	273	10.75
	W	100	3.94	100	3.94	100	3.94	100	3.94	120	4.72	160	6.30	160	6.30	220	8.66

Class 150-300-600

-API 602

&

-ASME B16.10

-ASME B16.10

			1/2		3/4		1		1-1/2		2	
		mm	in	mm	in	mm	in	mm	in	mm	in	
	Class 150	L	108	4.25	117	4.61	127	5	165	6.5	178	7.01
	Class 300	L	140	5.51	152	5.98	165	6.50	190	7.48	216	8.50
	Class 600	L	165	6.50	190	7.48	216	8.50	241	9.49	292	11.50
		D	12.2	0.39	12.2	0.48	18	0.71	29	1.14	37	1.46
		H	157	6.18	157	6.18	185	7.28	241	9.49	273	10.75
		W	100	3.94	100	3.94	120	4.72	160	6.30	220	8.66

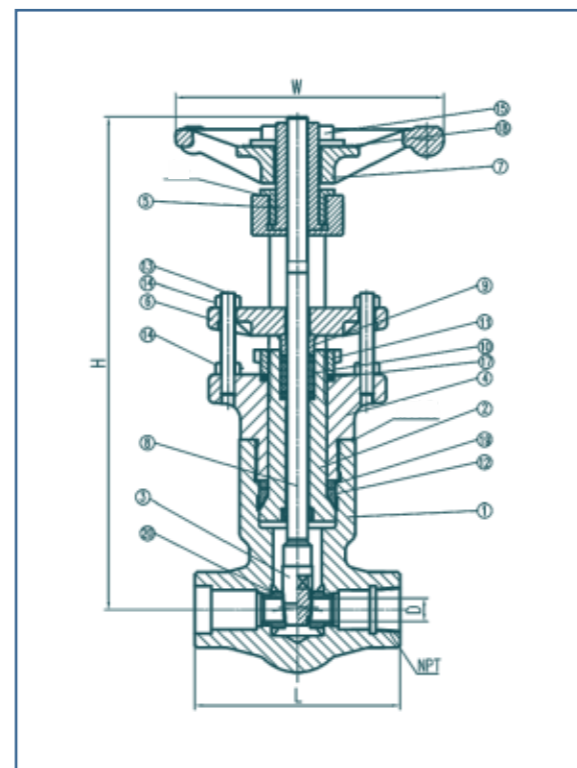
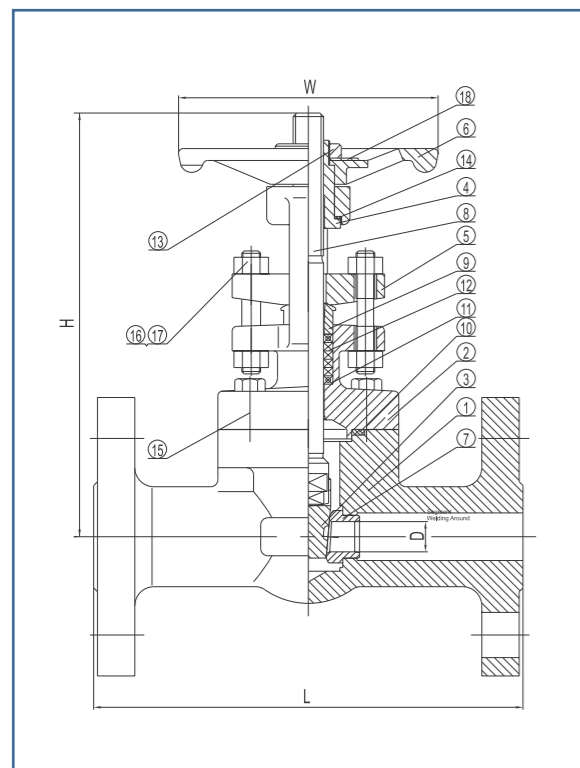
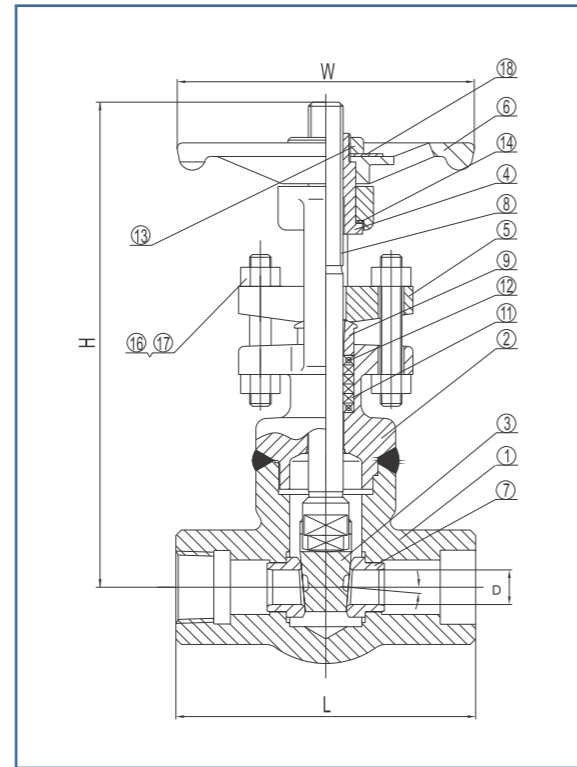
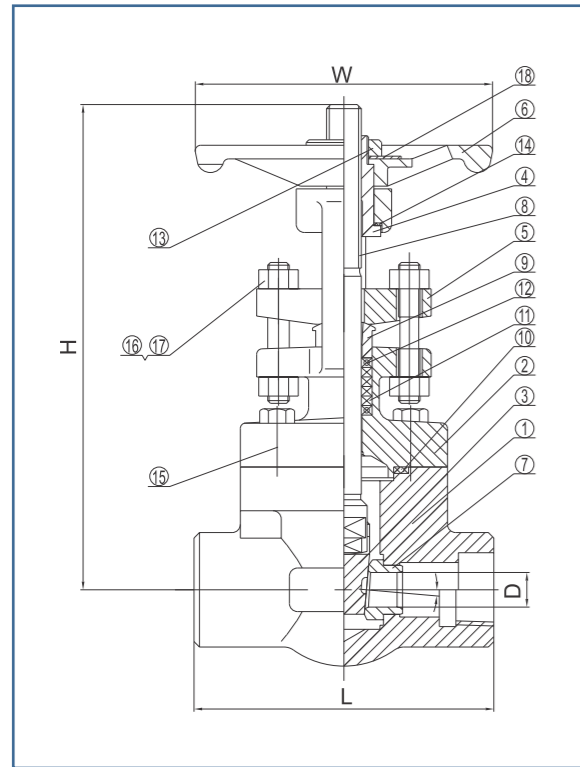

1	ASTM A105N	ASTM A182-F11/F22	ASTM A182 F304/F316
2	ASTM A105N	ASTM A182 F11/F22	ASTM A182 F304/F316
3	ASTM A182-F6a	ASTM A182-F6a	ASTM A182 F304/F316
4	ASTM A276-420	ASTM A276-420	ASTM A276-420
5	ASTMA216-WCB	ASTMA216-WCB	ASTMA351-CF8
6			
7	ASTM A276-410/STL.OVERLAY	ASTM A276-410/STL.OVERLAY	ASTM A182 F304/F316/ STL.6 OVERLAY
8	ASTM A182-F6a	ASTM A182-F6a	ASTM A182 F304/F316
9	ASTM A276-420	ASTM A276-420	ASTM A276-304/316
10	304SS/	304SS/	304SS/
11			
12	CARBON YARN	CARBON YARN	CARBON YARN
13	CARBON STEEL	CARBON STEEL	ASTM A276-304
14	ASTM A276-304	ASTM A276-304	ASTM A276-304
15	ASTM A193-B7	ASTM A193-B16	ASTM A193-B8
16	ASTMA193-B8	ASTMA193-B8	ASTMA193-B8
17	ASTM A194-8	ASTMA194-8	ASTM A194-8
18	ASTM A276-304	ASTM A276-304	ASTM A276-304

Class 800

-API 602

		3/8		1/2		3/4		1		1-1/4		1-1/2		2	
		1/4	3/8	1/2	3/4	1	1-1/4	1-1/2	2						
	L	mm	in	mm	in	mm	in	mm	in	mm	in	mm	in	mm	in
	D	76	2.99	76	2.99	86	3.39	102	4.02	118	4.65	118	4.65	132	5.2
	H	9.5	0.37	9.5	0.37	12.7	0.50	17.5	0.69	23.8	0.94	28.6	1.13	36.5	1.44
	W	157	6.19	157	6.19	165	6.51	192	7.57	272	10.70	277	10.92	283	11.15
	Weight	90	3.54	90	3.54	90	3.54	110	4.33	150	5.91	150	5.91	150	5.91
	Kg/Lb	1.5	3.31	1.5	3.31	2.0	4.41	3.0	6.61	4.0	8.82	5.5	12.13	7.5	16.53

Class 900/1500

-API 602

		3/8		1/2		3/4		1		1-1/4		1-1/2		2	
		1/4	3/8	1/2	3/4	1	1-1/4	1-1/2	2						
	L	mm	in	mm	in	mm	in	mm	in	mm	in	mm	in	mm	in
	D	90	3.54	90	3.54	104	4.09	120	4.72	130	5.12	130	5.12	150	5.91
	H	6.5	0.26	6.5	0.37	12.7	0.50	16	0.63	22.5	0.89	27	1.06	35	1.38
	W	163	6.41	163	6.41	190	7.47	225	8.85	263	10.33	264	10.41	319	12.57
	Weight	177	6.98	177	6.98	206	8.09	240	9.44	271	10.66	276	10.86	325	12.81
	Kg/Lb	90	3.54	90	3.54	110	4.33	150	5.91	150	5.91	150	5.91	180	7.09
	Kg/Lb	2.5	5.51	2.5	5.51	3.5	7.72	5.5	12.13	8.0	17.64	8.5	18.74	14.5	31.97

Class 900/1500

-API 602

		3/8		1/2		3/4		1		1-1/4		1-1/2		2	
		1/4		3/8		1/2		3/4		1		1-1/4		1-1/2	
		mm	in	mm	in	mm	in	mm	in	mm	in	mm	in	mm	in
L		-	-	120	4.72	120	4.72	140	5.51	178	7.01	178	7.01	216	8.50
D		-	-	9.5	0.37	12.7	0.37	16	0.63	27	1.06	27	1.06	35	1.38
H		-	-	230	9.06	294	11.57	337.5	13.29	396.5	15.61	396.5	15.61	449	17.68
W		-	-	110	4.33	110	4.33	150	5.91	150	5.91	150	5.91	180	7.09
	Kg/Lb	-	-	3.8	8.38	5.3	11.68	8.3	18.30	12.8	28.22	12.8	28.22	21.8	48.06

Class 2500

-ASME B16.34

		3/8		1/2		3/4		1		1-1/4		1-1/2		2	
		1/4		3/8		1/2		3/4		1		1-1/4		1-1/2	
		mm	in	mm	in	mm	in	mm	in	mm	in	mm	in	mm	in
L		-	-	178	7.01	178	7.01	186	7.32	232	9.13	232	9.13	279	10.98
D		-	-	9.0	0.35	12.0	0.47	15	0.59	27	1.06	27	1.06	35	1.38
H		-	-	295	11.61	295	11.61	345	13.58	410	16.14	410	16.14	460	18.11
W		-	-	150	5.91	150	5.91	180	7.09	250	9.84	250	9.84	350	13.78
	Kg/Lb	-	-	8.0	17.64	8.0	17.64	11	24.25	20	44.09	20	44.09	25	55.12

Class 2500

-ASME B16.34

		3/8		1/2		3/4		1		1-1/4		1-1/2		2	
		1/4		3/8		1/2		3/4		1		1-1/4		1-1/2	
		mm	in	mm	in	mm	in	mm	in	mm	in	mm	in	mm	in
L		-	-	178	7.01	178	7.01	186	7.32	232	9.13	232	9.13	279	10.98
D		-	-	9.0	0.35	12.0	0.47	15	0.59	27	1.06	27	1.06	35	1.38
H		-	-	393	15.08	383	15.08	406.5	16.00	454.5	17.89	454.5	17.89	540	21.26
W		-	-	150	5.91	150	5.91	180	7.09	250	9.84	250	9.84	350	13.78
	Kg/Lb	-	-	8.0	22.05	10.0	22.05	13	28.66	21.8	48.06	21.8	48.06	28	61.73

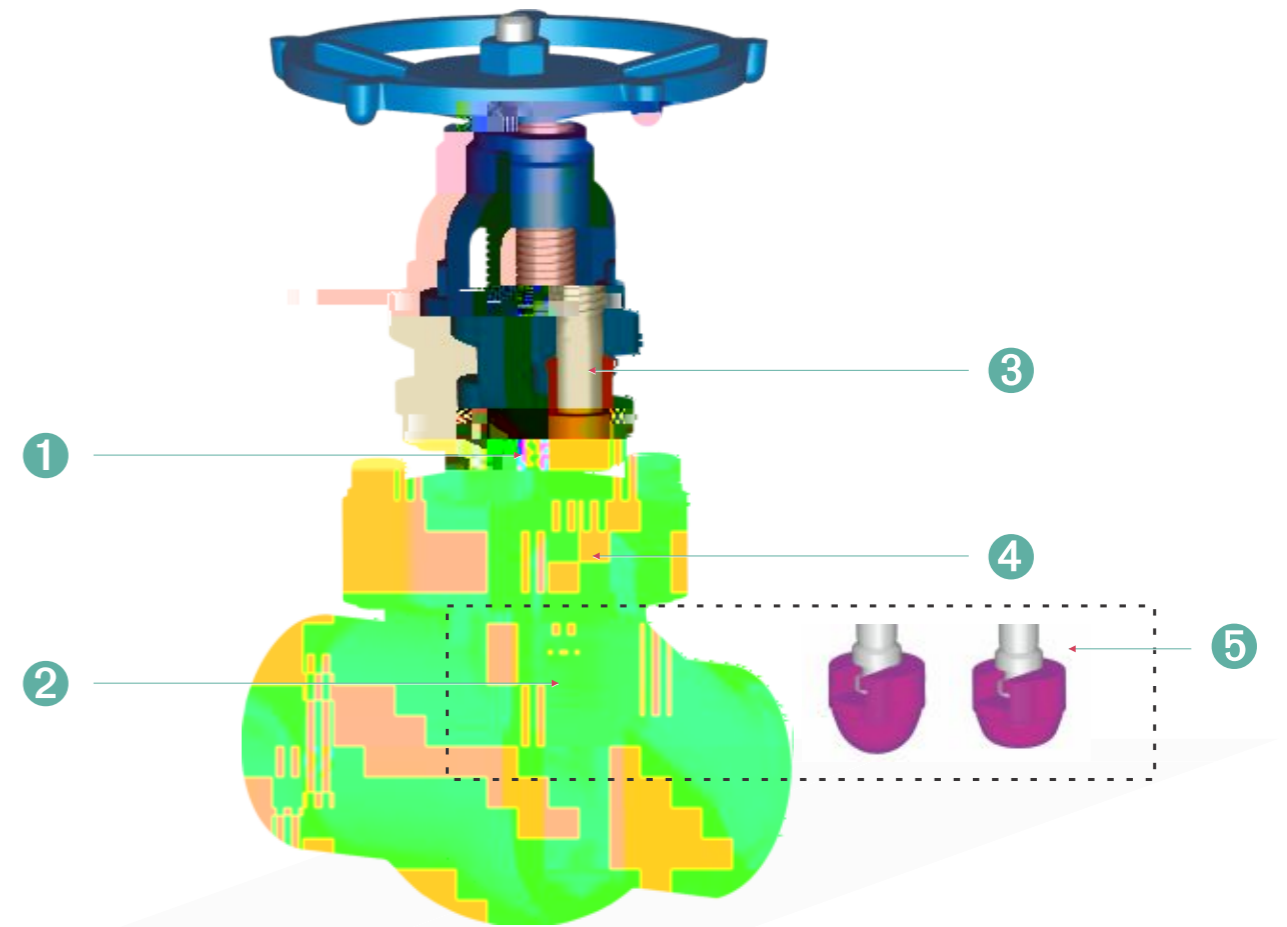

1

2

3

4

5

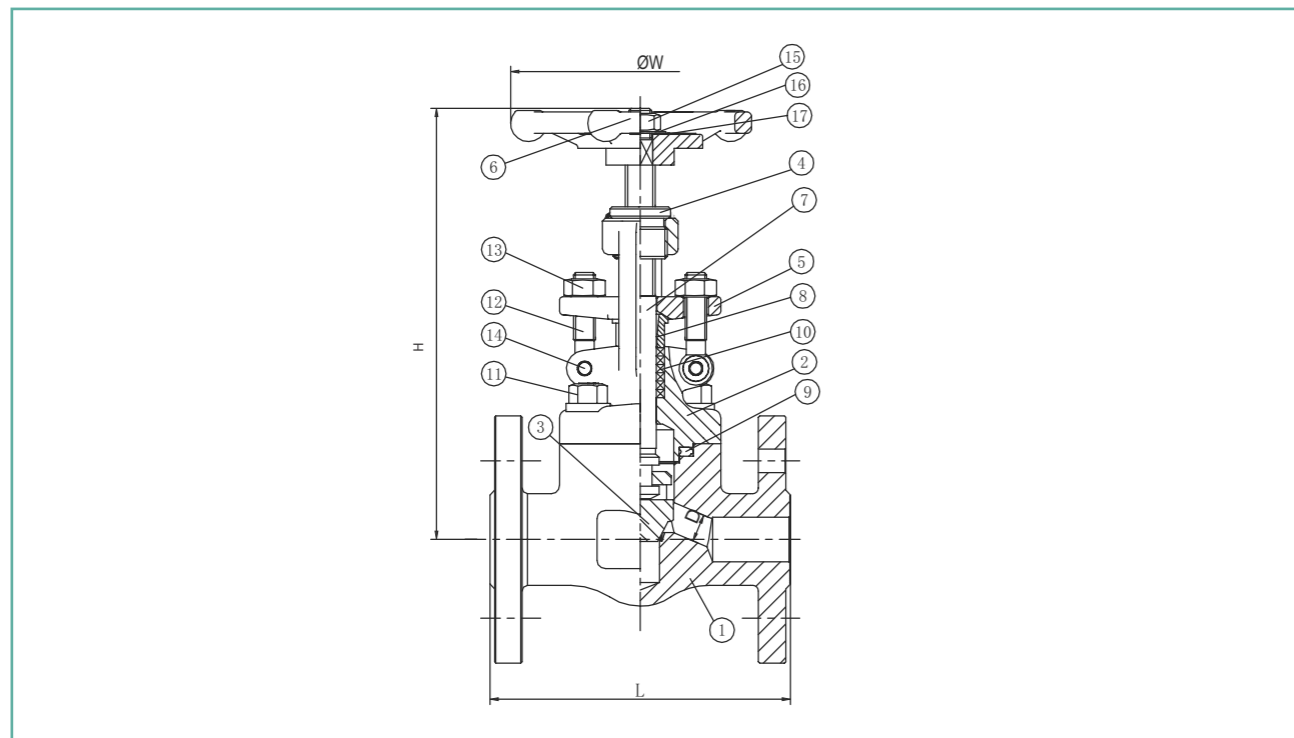
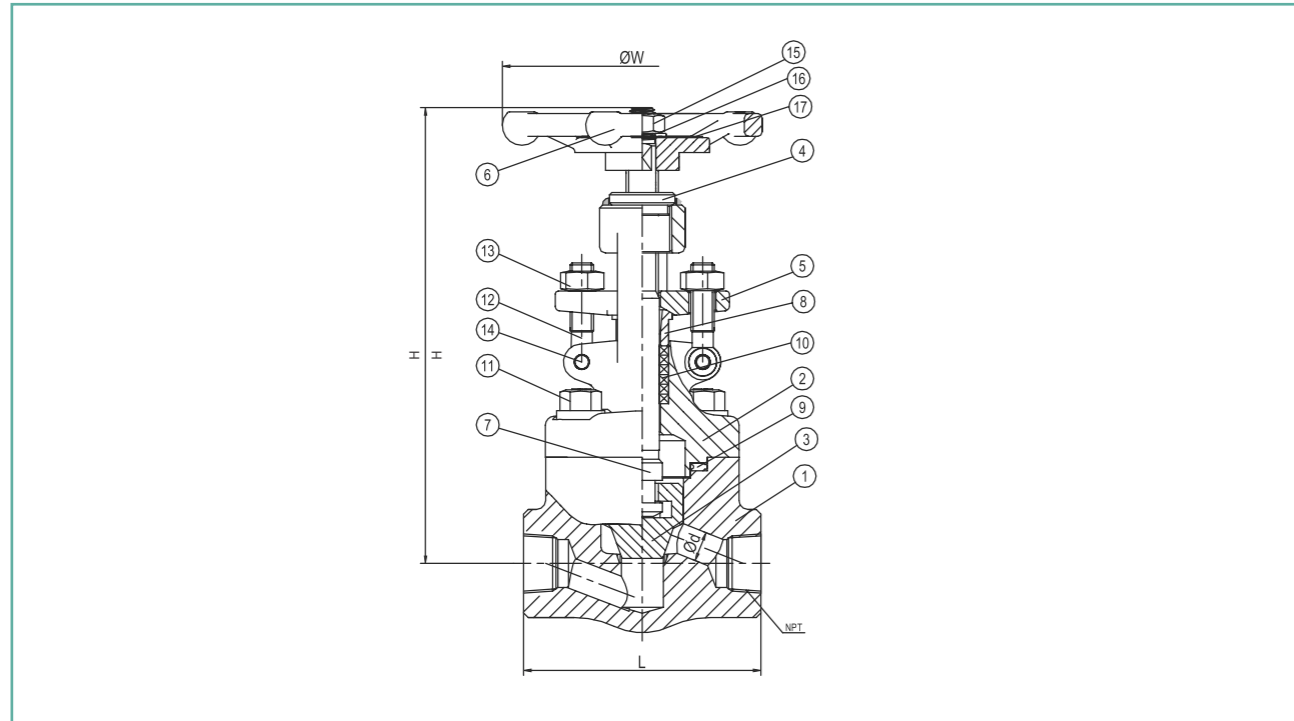

1		ASTM A105N/STL.6 OVERLAY	ASTM A182 F11/F22/ STL.6 OVERLAY	ASTM A182 F304/F316/ STL.6 OVERLAY
2		ASTM A105N	ASTM A182 F11/F22	ASTM A182 F304/F316
3		ASTM A276 410	ASTM A276 410	ASTM A182 F304/F316
4		ASTM A276 410	ASTM A276 410	ASTM A276-410
5		ASTM A105N	ASTM A105N	ASTM A182 F316
6		ASTM A197	ASTM A197	ASTM A197
7		ASTM A276 410	ASTM A276 410	ASTM A182 F304/F316
8		ASTM A276 420	ASTM A276 420	ASTM A276 316
9		/316L SS	缠绕石墨/316L SS	缠绕石墨/316L SS
10				
11		ASTM A193-B7	ASTM A193-B16	ASTM A193-B8
12		ASTM A193-B7	ASTM A193-B16	ASTM A193-B8
13		ASTM A194-2H	ASTM A194-7	ASTM A194-8
14		ASTM A276 304	ASTM A276 304	ASTM A276 316
15		ASTM A194-2H	ASTM A194-7	ASTM A194-8
16		ASTM A276-410	ASTM A276-410	ASTM A276-410
17		304SS	304SS	304SS

Class 800

-API 602

		1/4		3/8		1/2		3/4		1		1-1/4		1-1/2		2	
		mm	in	mm	in	mm	in	mm	in	mm	in	mm	in	mm	in	mm	in
	L	76	3.11	79	3.11	79	3.11	92	3.62	111	4.37	120	4.72	152	5.98	172	6.77
	D	6.8	0.27	6.8	0.27	9.5	0.37	13	0.51	18	0.69	23.5	0.93	28.5	1.12	36.5	1.44
	H	161	6.34	161	6.34	167	6.57	167	6.57	196	7.72	236	9.29	252	9.92	282	11.10
	W	100	3.94	100	3.94	100	3.94	100	3.94	120	4.72	160	6.30	160	6.30	220	8.66

Class 150-300-600

-API 602

&

-ASME B16.10

-ASME B16.10

		1/2		3/4		1		1-1/4		1-1/2		2		
		mm	in	mm	in	mm	in	mm	in	mm	in	mm	in	
	Class 150	L	108	4.25	117	4.61	127	5	140	5.51	165	6.50	203	7.99
	Class 300	L	152	5.98	178	7.01	203	7.99	-	-	229	9.02	267	10.51
	Class 600	L	165	6.50	190	7.48	216	8.50	-	-	241	9.49	292	11.50
		D	9.5	0.37	13	0.51	18	0.69	23.5	0.93	28.5	1.12	36.5	1.44
		H	167	6.57	167	6.57	196	7.72	236	9.29	252	9.92	282	11.10
		W	100	3.94	100	3.94	120	4.72	160	6.30	160	6.30	220	8.66

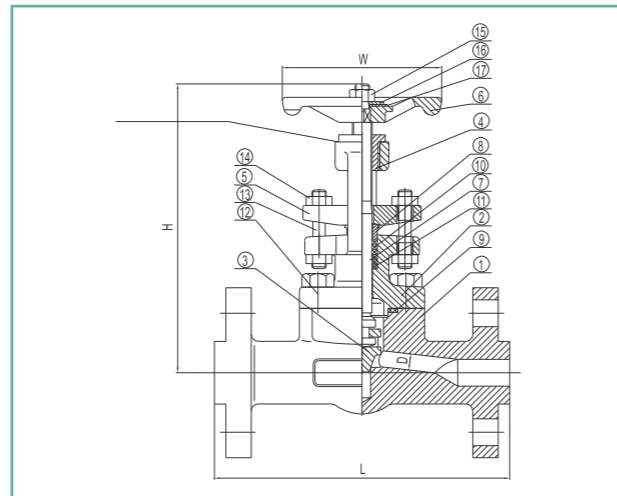
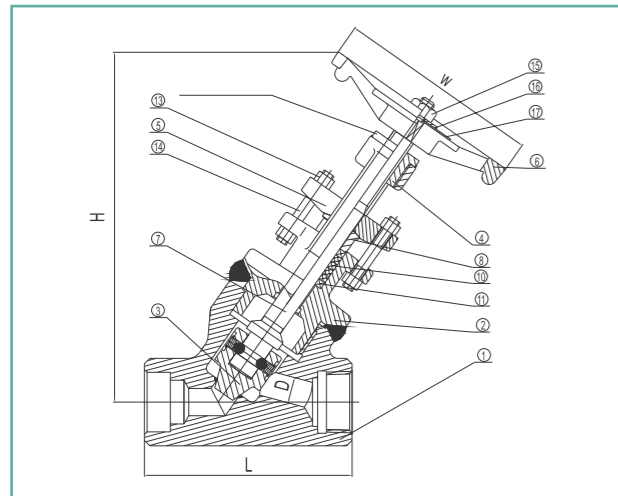
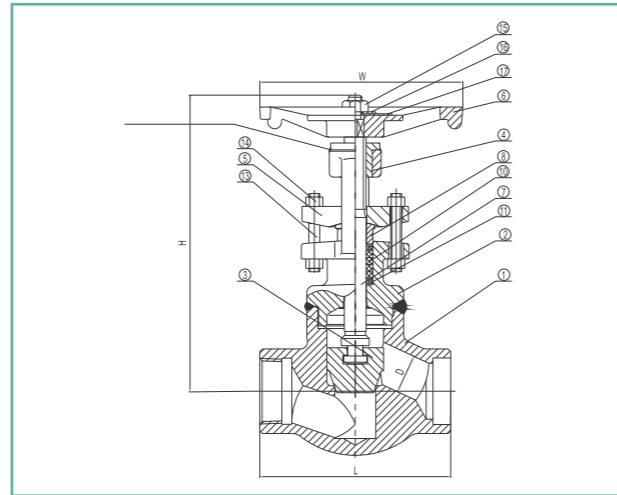
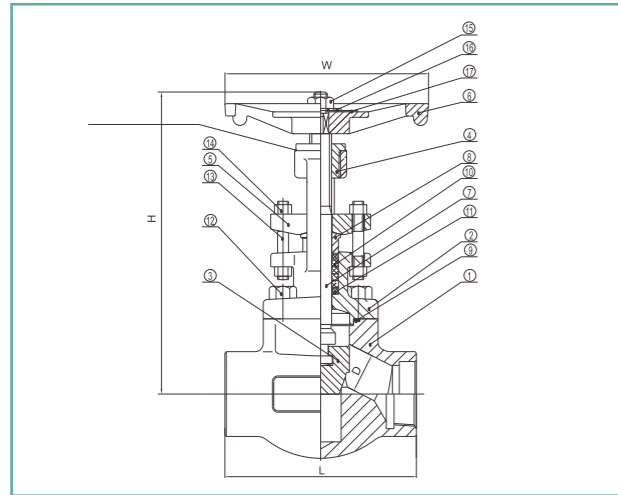

Y

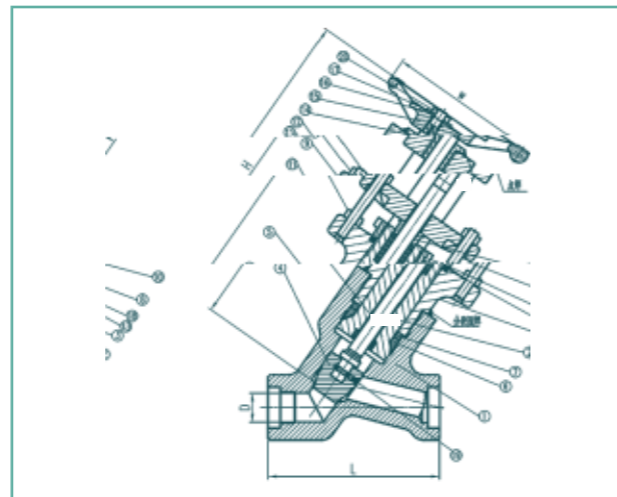
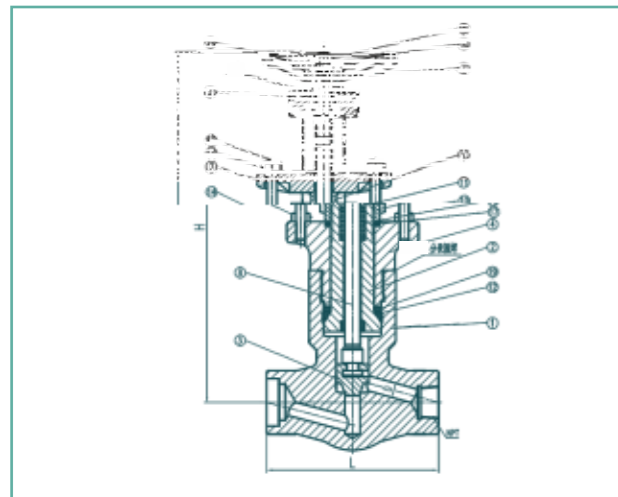

Y

1	ASTM A105/STLOVERLAY	ASTMA182-F11/F22/STL	ASTM A182-F304/F316/STL
2	ASTM A105	ASTM A182 F11/F22	ASTM A182 F304/F316
3	ASTM A182-F6a	ASTM A182-F6a	ASTM A182 F304/F316
4	ASTM A276-420	ASTM A276-420	ASTM A276-420
5	ASTM A216-WCB	ASTM A216-WCB	ASTM A351-CF8
6	DUCTILE IRON	DUCTILE IRON	DUCTILE IRON
7	ASTMA182-F6a	ASTMA182-F6a	ASTM A182 F304/F316
8	ASTM A276-420	ASTM A276-420	ASTM A276-304/316L
9	304SS/	304SS/	304SS/
10			
11			
12	ASTM A193-B7	ASTM A193-B16	ASTM A193-B8
13	ASTM A193-B8	ASTM A193-B8	ASTM A193-B8
14	ASTM A194-8	ASTM A194-8	ASTM A194-8
15			ASTM A276-304
16			ASTM A276-304
17	ASTM A276-304	ASTM A276-304	ASTM A240-304

Class 800

-API 602

		3/8		1/2		3/4		1		1-1/4		1-1/2		2	
		mm	in	mm	in	mm	in	mm	in	mm	in	mm	in	mm	in
	L	76	2.99	76	2.99	86	3.39	102	4.02	140	5.51	140	5.51	170	6.69
	D	6.5	0.26	9.5	0.37	12.7	0.50	17.5	0.69	23.0	0.91	28.6	1.13	36.5	1.44
	H	150.8	5.94	150.8	5.94	166.8	6.57	206.3	8.12	270.3	10.64	281.3	11.07	350.3	13.79
	W	90	3.54	90	3.54	90	3.54	110	4.33	150	5.91	150	5.91	150	5.91
	Kg/Lb	2.0	4.41	2.0	4.41	2.5	5.51	3.5	7.72	7.0	15.43	7.0	15.43	10.5	23.15

Class 900/1500

-API 602

		3/8		1/2		3/4		1		1-1/4		1-1/2		2	
		mm	in	mm	in	mm	in	mm	in	mm	in	mm	in	mm	in
	L	90	3.54	90	3.54	104	4.09	120	4.72	150	5.91	150	5.91	180	7.09
	D	8.0	0.31	9.0	0.35	12.0	0.47	15	0.59	21	0.83	27	1.06	32	1.26
	H	165.7	6.52	165.7	6.52	191.8	7.55	226.8	8.93	278.3	10.96	280.3	11.04	312.3	12.30
		179.7	7.07	179.7	7.07	207.3	8.16	239.7	9.44	281.8	11.09	285.8	11.25	316.3	12.45
	W	90	3.54	90	3.54	110	4.33	150	5.91	150	5.91	180	7.09	180	7.09
	Kg/Lb	2.5	5.51	2.5	5.51	3.0	6.61	5.5	12.13	8.5	18.74	8.5	18.74	14.5	31.97

Class 900/1500

-API 602

		3/8		1/2		3/4		1		1-1/4		1-1/2		2	
		1/4		3/8		1/2		3/4		1		1-1/4		1-1/2	
L		mm	in	mm	in	mm	in	mm	in	mm	in	mm	in	mm	in
	L	120	4.72	120	4.72	120	4.72	-	-	165	6.50	178	7.01	216	8.5
	D	8.0	0.31	9.0	0.35	12.0	0.47	-	-	21	0.83	27	1.06	30	1.18
	H	285.3	11.23	85.3	11.23	285.3	11.23	-	-	395.8	15.58	395.8	15.58	446.8	17.59
	W	150	5.91	150	5.91	150	5.91	-	-	200	7.87	200	7.87	250	9.84
	Kg/Lb	7.5	16.53	7.5	16.53	7.5	16.53	-	-	18.5	40.79	19.0	41.89	28.5	62.83

Class 2500

-ASME B16.34

		3/8		1/2		3/4		1		1-1/4		1-1/2		2	
		1/4		3/8		1/2		3/4		1		1-1/4		1-1/2	
L		mm	in	mm	in	mm	in	mm	in	mm	in	mm	in	mm	in
	L	120	4.72	120	4.72	140	5.51	186	7.32	232	9.13	232	9.13	279	10.98
	D	8.0	0.31	9.0	0.35	12.0	0.47	15	0.59	19	0.75	27	1.06	27	1.06
	H	205	8.07	205	8.07	260	10.24	302	11.89	340	13.39	340	13.39	390	15.35
	W	150	5.91	150	5.91	180	7.09	200	7.87	250	9.84	250	9.84	350	13.78
	Kg/Lb	7.5	16.53	7.5	15.43	9.0	19.84	15.5	34.17	26	57.32	26	57.32	36	79.37

Class 2500

-ASME B16.34

		3/8		1/2		3/4		1		1-1/4		1-1/2		2	
		1/4		3/8		1/2		3/4		1		1-1/4		1-1/2	
L		mm	in	mm	in	mm	in	mm	in	mm	in	mm	in	mm	in
	L	120	4.72	120	4.72	140	5.51	186	7.32	232	9.13	232	9.13	279	10.98
	D	8.0	0.31	9.0	0.35	12.0	0.47	15	0.59	19	0.75	27	1.06	27	1.06
	H	295.3	11.63	295.3	11.62	346.3	13.63	389.3	15.33	430.4	16.94	430.4	16.94	478.8	18.85
	W	150	5.91	150	5.91	180	7.09	200	7.87	250	9.84	250	9.84	350	13.78
	Kg/Lb	7.5	16.53	7.5	16.53	12.0	26.46	19.5	42.99	28	61.73	28	61.73	40	88.18

Class 900/1500

-API 602

-ASME B16.10
-ASME B16.5

		1/2		3/4		1		1-1/2		2	
L		mm	in	mm	in	mm	in	mm	in	mm	in
	L	216	8.50	229	9.02	254	10.00	305	12.01	368	14.49
	D	9.0	0.35	12.0	0.47	15.0	0.59	27.0	1.06	32.0	1.26
	H	165.7	6.52	191.8	7.55	226.8	8.93	280.3	11.04	312.3	12.30
	W	90	3.54	110	4.33	150	5.91	180	7.09	180	7.09
	Kg/Lb	7.0	15.43	9.0	19.84	14.5	31.97	22	48.50	40	88.18

Class 800 Y

-API 602

		3/8		1/2		3/4		1		1-1/4		1-1/2		2	
L		mm	in	mm	in	mm	in	mm	in	mm	in	mm	in	mm	in
	L	80	3.15	80	3.15	90	3.54	110	4.33	125	4.92	155	6.10	180	7.09
	D	9.5	0.37	12	0.47	17	0.67	23	0.91	28	1.10	36	1.42	44	1.73
	H	170	6.69	170	6.69	200	7.87	242	9.53	276	10.87	295	11.61	327	12.87
	W	90	3.54	90	3.54	110	4.33	150	5.91	150	5.91	150	5.91	180	7.09
	Kg/L	2.0	4.41	2.5	5.51	3.5	7.72	5.0	11.02	6.5	14.33	8.0	17.64	12.5	27.56

Class 900-1500 Y

-API 602

		3/8		1/2		3/4		1		1-1/4		1-1/2		2	
L		mm	in	mm	in	mm	in	mm	in	mm	in	mm	in	mm	in
	L	80	3.15	90	3.54	110	4.33	125	4.92	155	6.10	180	7.09	200	7.87
	D	9.5	0.37	12	0.47	15	0.59	21	0.83	27	1.06	32	1.26	38	1.50
	H	170	6.69	200	7.87	238	9.37	272	10.71	308	12.13	326	12.83	376	14.80
	W	90	3.54	110	4.33	150	5.91	150	5.91	180	7.09	180	7.09	200	7.87
	Kg/L	2.8	6.17	4.0	8.82	5.0	11.02	7.5	16.53	9.0	19.84	13	28.66	18	39.68

Class 2500 Y

-ASME B16.34

		3/8		1/2		3/4		1		1-1/2		2	
L		mm	in	mm	in	mm	in	mm	in	mm	in	mm	in
	L	-	-	110	4.33	125	4.92	180	7.09	200	7.87	230	9.06
	D	-	-	12	0.47	15	0.59	21	0.83	28	1.10	35	1.38
	H	-	-	239.6	9.43	274.1	10.79	325.5	12.81	372.9	14.68	446.2	17.57
	W	-	-	150	5.91	150	5.91	180	7.09	200	7.87	300	11.81
	Kg/Lb	-	-	5.5	12.13	7.5	16.53	13.5	29.76	18.5	40.79	25	55.12

Class 900-1500 Y

-API 602

		1/2		3/4		1		1-1/2		2	
L		mm	in	mm	in	mm	in	mm	in	mm	in
	L	140	5.51	140	5.51	140	5.51	178	7.01	216	8.50
	D	10	0.39	15	0.59	21	0.83	32	1.26	38	1.50
	H	350	13.78	350	13.78	350	13.78	450	17.72	450	17.72
	W	200	7.87	200	7.87	200	7.87	250	9.84	300	11.81
	Kg/Lb	9.0	19.84	9.5	20.94	11.5	25.35	16.5	36.38	30	66.14

Class 2500 Y

-ASME B16.34

		1/2		3/4		1		1-1/2		2	
L		mm	in	mm	in	mm	in	mm	in	mm	in
	L	140	5.51	178	7.01	216	8.5	216	8.5	279	10.98
	D	12	0.47	15	0.59	21	0.83	28	1.10	38	1.50
	H	380	14.96	405	15.94	430	16.93	480	18.90	520	20.47
	W	180	7.09	200	7.87	250	9.84	350	13.78	350	13.78
	Kg/Lb	10	22.05	13	28.66	15	33.07	25	55.12	42.5	93.70

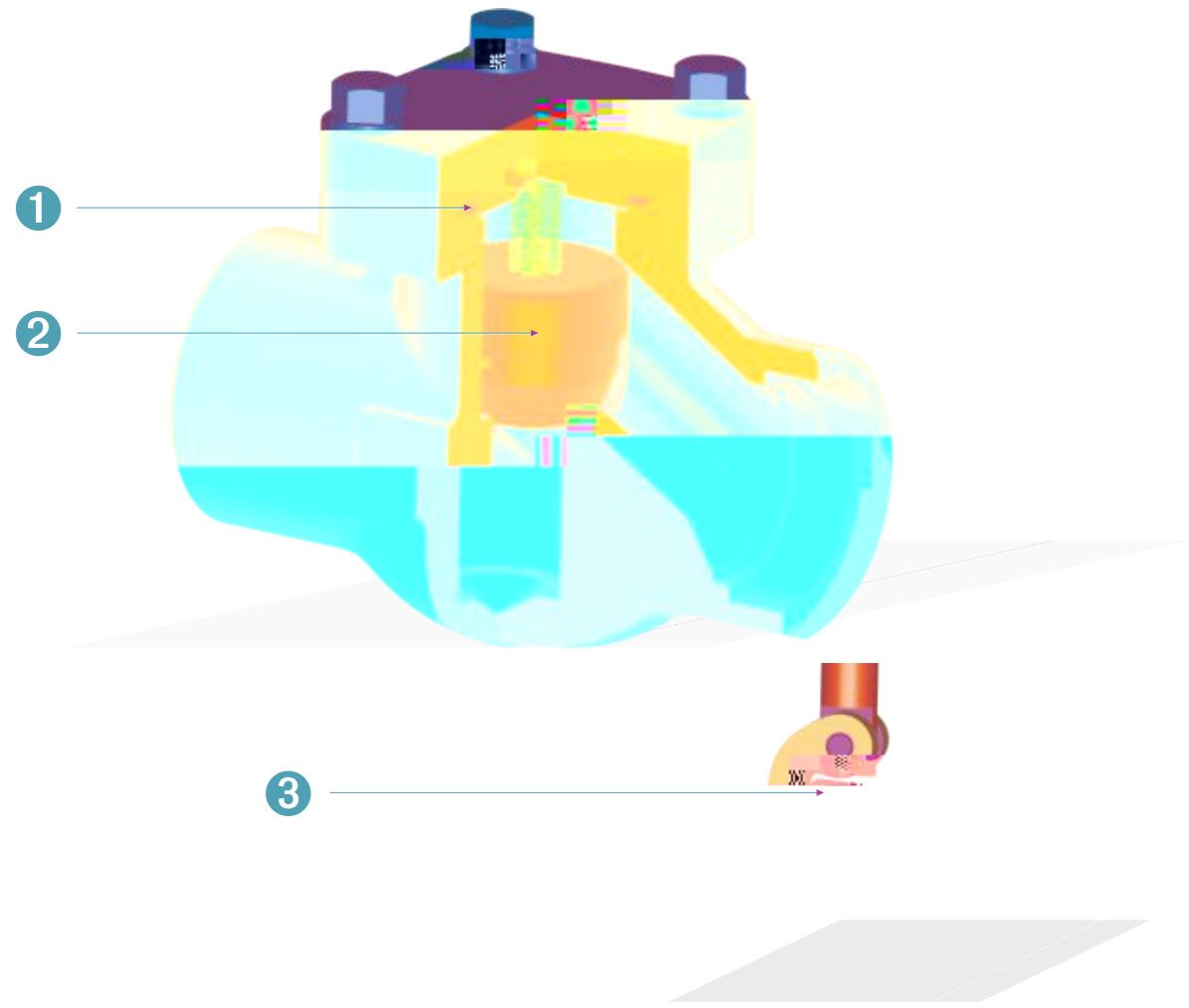

1

2

3

1

2

3

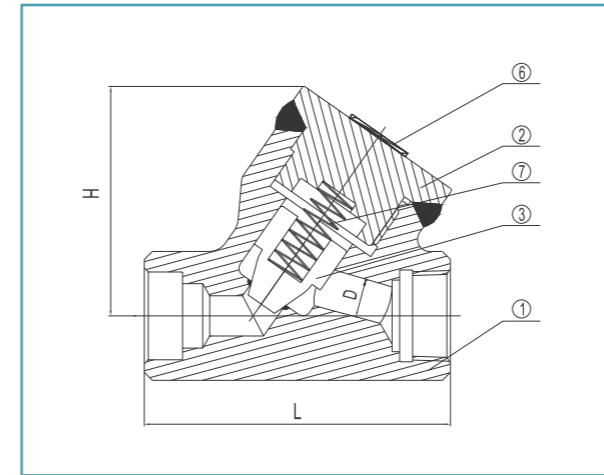
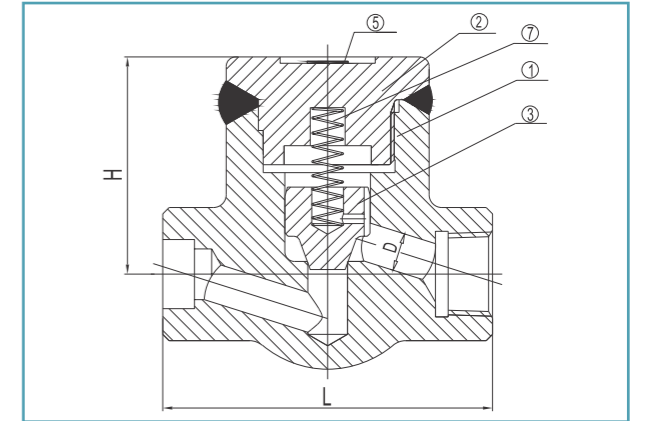
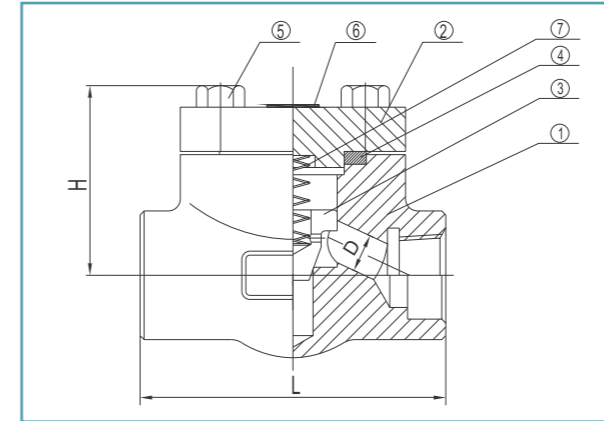

Y

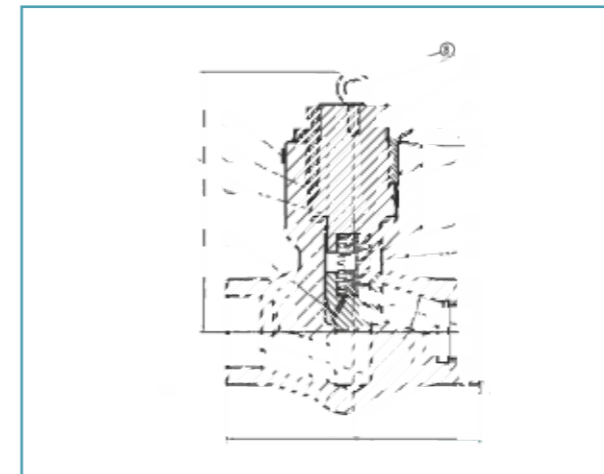
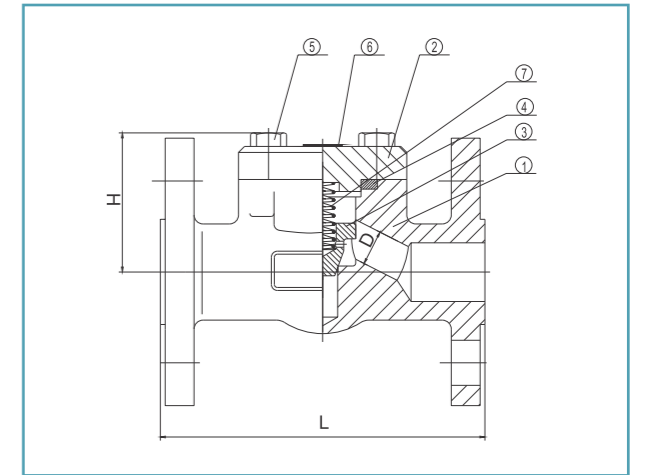

1	ASTM A105/STL.OVERLAY	ASTM A182-F11/F22/STL	ASTMA182-F304/F316/STLOVERLAY
2	ASTM A105	ASTM A182-F11/F22	ASTM A182-F304/F316
3	ASTM A182-F6a	ASTM A182-F6a	ASTM A182-F304/F316
4	304	304	304/316
5	ASTM A193-B7	ASTM A193-B16	ASTM A193-B8
6	ASTM A276 304	ASTM A276 304	ASTM A276 304
7	ASTM A276 316	ASTM A276-316	ASTM A276-316

Class 800

-API 602

		3/8		1/2		3/4		1		1-1/4		1-1/2		2	
		1/4		3/8		1/2		3/4		1		1-1/4		1-1/2	
	L	mm	in	mm	in	mm	in	mm	in	mm	in	mm	in	mm	in
	D	76	2.99	76	2.99	86	3.39	102	4.02	140	5.51	140	5.51	170	6.69
	H	6.5	0.26	9.5	0.37	12.7	0.50	17.5	0.69	23	0.91	28.6	1.13	36.5	1.44
	Kg/Lb	48	1.89	48	1.89	53	2.09	64	2.52	80	3.15	80	3.15	100	3.94
		49	1.93	49	1.93	58	2.28	70	2.76	96	3.78	90	3.54	125	4.92
		1	2.2	1	2.20	1.5	3.31	2	4.41	4.5	9.92	6	13.23	7.5	16.53

Class 900-1500

-API 602

		1/2		3/4		1		1-1/4		1-1/2		2	
		3/8		1/2		3/4		1		1-1/4		1-1/2	
	L	mm	in	mm	in	mm	in	mm	in	mm	in	mm	in
	D	90	3.54	104	4.09	120	4.72	150	5.91	150	5.91	180	7.09
	H	9	0.35	12	0.47	15	0.59	21	0.83	27	1.06	32	1.26
	Kg/Lb	56	2.20	62	2.44	72	2.83	92.5	3.64	92.5	3.64	111	4.37
		61.5	2.42	68.5	2.70	72.5	2.85	83.5	3.29	83.5	3.29	100.5	3.96
		1.5	3.31	2.5	5.51	4	8.82	6	13.23	8.5	18.74	14.5	31.97

Class 900-1500

-API 602

		1/2		3/4		1		1-1/4		1-1/2		2	
		3/8		1/2		3/4		1		1-1/4		1-1/2	
	L	mm	in	mm	in	mm	in	mm	in	mm	in	mm	in
	D	120	4.72	120	4.72	140	5.51	165	6.50	186	7.32	232	9.13
	H	9	0.35	12	0.47	15	0.59	21	0.83	27	1.06	30	1.18
	Kg/Lb	188	7.40	188	7.40	196	7.72	220	8.66	220	8.66	238	9.37
		5	11.02	6.5	14.33	8	17.64	13.5	29.76	15	33.07	25	55.12

Class 2500

-ASME B16.34

		1/2		3/4		1		1-1/4		1-1/2		2	
		3/8		1/2		3/4		1		1-1/4		1-1/2	
	L	mm	in	mm	in	mm	in	mm	in	mm	in	mm	in
	D	120	4.72	140	5.51	186	7.32	-	-	232	9.13	279	10.98
	H	9	0.35	12	0.47	15	0.59	-	-	27	1.06	27	1.06
	Kg/Lb	90	3.54	100	3.94	115	4.53	-	-	140	5.51	160	6.30
		3.5	7.72	5.5	12.13	10.5	23.15	-	-	18.5	40.79	25	55.12

Class 2500

-ASME B16.34

		1/2		3/4		1		1-1/4		1-1/2		2	
		3/8		1/2		3/4		1		1-1/4		1-1/2	
	L	mm	in	mm	in	mm	in	mm	in	mm	in	mm	in
	D	120	4.72	140	5.51	186	7.32	-	-	232	9.13	279	10.98
	H	9	0.35	12	0.47	15	0.59	-	-	27	1.06	27	1.06
	Kg/Lb	172	6.77	195	7.68	214	8.43	-	-	241	9.49	260	10.24
		3.5	7.72	5.5	12.13	10.5	23.15	-	-	18.5	40.79	25	55.12

Class 800 Y

-API 602

		3/8		1/2		3/4		1		1-1/4		1-1/2		2	
	L	mm	in	mm	in	mm	in	mm	in	mm	in	mm	in	mm	in
	D	80	3.15	80	3.15	90	3.54	110	4.33	125	4.92	155	6.10	180	7.09
	H	9.5	0.37	12	0.47	17	0.67	23	0.91	28	1.10	36	1.42	44	1.73
	Kg/Lb	68.5	2.70	68.5	2.70	78.5	3.09	89.5	3.52	105.5	4.15	123.5	4.86	147.5	5.81
		1	2.20	1.5	3.31	2	4.41	4.5	9.92	8	17.64	8	17.64	11	24.25

Class 900-1500 Y

-API 602

		3/8		1/2		3/4		1		1-1/4		1-1/2		2	
	L	mm	in	mm	in	mm	in	mm	in	mm	in	mm	in	mm	in
	D	80	3.15	90	3.54	110	4.33	125	4.92	155	6.10	180	7.09	200	7.87
	H	9.5	0.37	12	0.47	15	0.59	21	0.83	27	1.06	32	1.26	38	1.50
	Kg/Lb	71.8	2.83	82.5	3.25	84.2	3.31	104.7	4.12	121.7	4.79	143.3	5.64	55.2	6.11
		2	4.41	3	6.61	4.2	9.26	5.2	11.46	9.5	20.94	11	24.2	15	33.07

Class 150-300-600

-API 602

-ASME B16.5

-ASME B16.10

		1/2		3/4		1		1-1/4		1-1/2		2		
		mm	in	mm	in	mm	in	mm	in	mm	in	mm	in	
	Class 150	L	108	4.25	117	4.61	127	5	140	5.51	165	6.50	203	7.99
	Class 300	L	152	5.98	178	7.01	203	7.99	-	-	229	9.02	267	10.51
	Class 600	L	165	6.50	190	7.48	216	8.50	-	-	241	9.49	292	11.50
		D	9.5	0.37	12.7	0.50	17.5	0.69	23	0.91	28.6	1.13	36.5	1.44
		H	50	1.97	54	2.13	68	2.68	78	3.07	78	3.07	96	3.78
	Class 150		2.5	5.51	3.3	7.28	4.3	9.48	6.5	14.33	9	19.84	13	28.66
	Class 300	Kg/Lb	3.0	6.61	3.8	8.38	5.2	11.46	-	-	10.5	23.15	15	33.07
	Class 600		3.5	7.72	4.5	9.92	6.0	13.23	-	-	12	26.46	17	37.48

Class 900-1500

-API 602

-ASME B16.5

-ASME B16.10

		1/2		3/4		1		1-1/4		2	
		mm	in	mm	in	mm	in	mm	in	mm	in
	L	216	8.50	229	9.02	254	10	305	12.01	368	14.49
	D	9	0.35	12	0.47	15	0.59	27	1.06	32	1.26
	H	53	2.09	60	2.36	70	2.76	86	3.39	105	4.13
	Kg/Lb	6	13.23	7.5	16.53	12	26.46	21	46.30	32.5	71.65

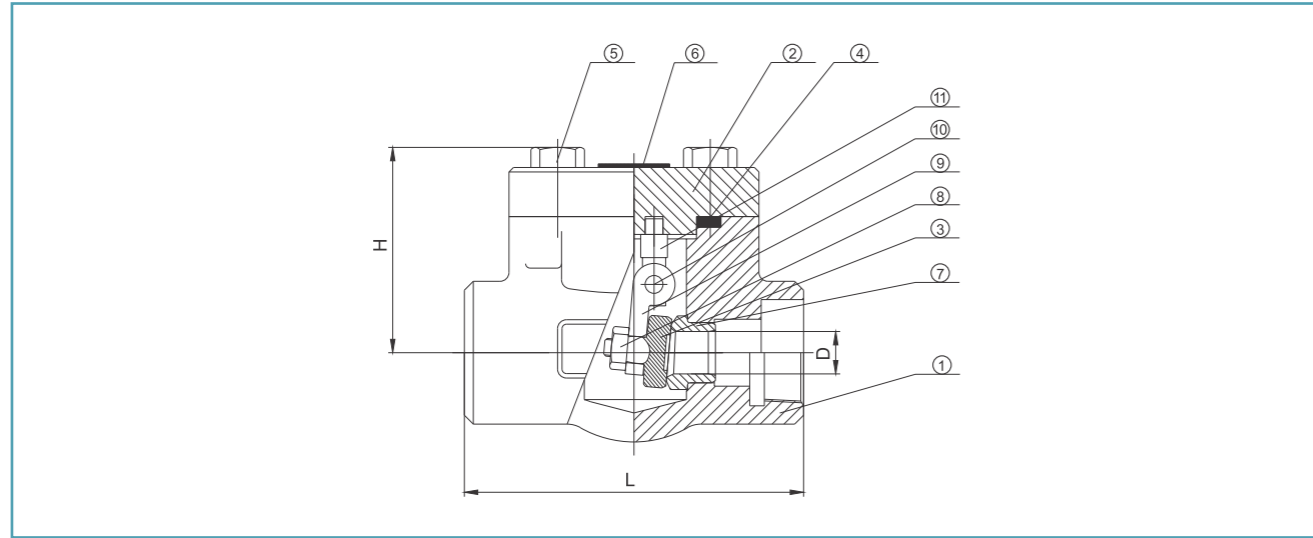

1	ASTMA105	ASTMA182-F11/F22	ASTMA182-F304/F316
2	ASTMA105	ASTMA182-F11/F22	ASTMA182-F304/F316
3	ASTMA182-F6a	ASTMA182-F6a	ASTMA182-F304/F316
4	304	304SS/	304/316SS/
5	ASTMA193-B7	ASTMA193-B16	ASTMA193-B8
6	ASTMA276 304	ASTMA240-304	ASTMA240-304
7	ASTMA276-410/STLOVERLAY	ASTMA276-410/STLOVERLAY	ASTMA182-F304/F316/STLOVERLAY
8	ASTMA276-304	ASTMA276-304	ASTMA276-304/316
9	ASTMA216-WCB	ASTMA217-WC6/WC9	ASTMA351-CF8/CF8M
10	ASTMA276-410	ASTMA276-410	ASTMA276-F304/316
11	ASTMA105	ASTMA182-F11/F22	ASTMA182-F304/F316

Class 800

-API 602

	1/2		3/4		1		1-1/4		1-1/2		2	
	3/8		1/2		3/4		1		1-1/4		1-1/2	
L	mm	in	mm	in	mm	in	mm	in	mm	in	mm	in
		76	2.99	86	3.39	102	4.02	118	4.65	118	4.65	132
D	9.5	0.37	12.7	0.50	17.5	0.69	23.8	0.94	28.6	1.13	36.5	1.44
H	48.5	1.91	52	2.05	67	2.64	88	3.46	88	3.46	101	3.98
Kg/Lb	1.5	3.31	2.3	5.07	2.8	6.17	4.0	8.82	5.7	12.57	7.7	16.98

Class 900-1500

-API 602

	1/2		3/4		1		1-1/4		1-1/2		2	
	3/8		1/2		3/4		1		1-1/4		1-1/2	
L	mm	in	mm	in	mm	in	mm	in	mm	in	mm	in
		90	3.54	104	4.09	120	4.72	130	5.12	130	5.12	132
D	9.5	0.37	12.7	0.50	16	0.63	27	1.6	27	1.06	36.5	1.44
H	57.5	2.26	66	2.60	78.5	3.09	106	4.17	106	4.17	101	3.98
Kg/Lb	1.8	3.97	2.5	5.51	3.8	8.38	6.5	14.33	6.5	14.33	7.7	16.98

Class 150-300-600

-API602

-ASME B16.5

-ASME B16.10

		1/2		3/4		1		1-1/2		2	
		mm	in	mm	in	mm	in	mm	in	mm	in
Class 150	L	108	4.25	117	4.61	127	5.0	165	6.50	203	7.99
Class 300	L	152	5.98	178	7.01	216	8.50	241	9.49	267	10.51
Class 600	L	165	6.50	190	7.48	216	8.50	241	9.49	292	11.50
	D	9.5	0.37	12.7	0.50	17.5	0.69	28.6	1.13	36.5	1.44
	H	48.5	1.91	52	2.05	67	2.64	88	3.46	101	3.98
Class 150		2.5	5.51	3.3	7.28	4.3	9.48	9.0	19.84	13	28.66
Class 300	Kg/Lb	3.0	6.61	3.8	8.38	5.2	11.46	10.5	23.15	15	33.07
Class 600		3.5	7.72	4.5	9.92	6.0	13.23	12	26.46	17	37.48

Class 2500

-ASME B16.34

		1/2		3/4		1		1-1/2		2	
		3/8		1/2		3/4		1-1/4		1-1/2	
L	mm	in	mm	in	mm	in	mm	in	mm	in	
		178	7.01	178	7.01	186	7.32	232	9.13	279	10.97
D	9.0	0.35	12.0	0.47	15	0.59	27	1.06	34.5	1.36	
H	81	3.19	81	3.19	94	3.70	158	6.22	180	7.09	
Kg/Lb	4.5	9.92	7.5	16.53	8.0	17.64	15	33.07	19.5	42.99	

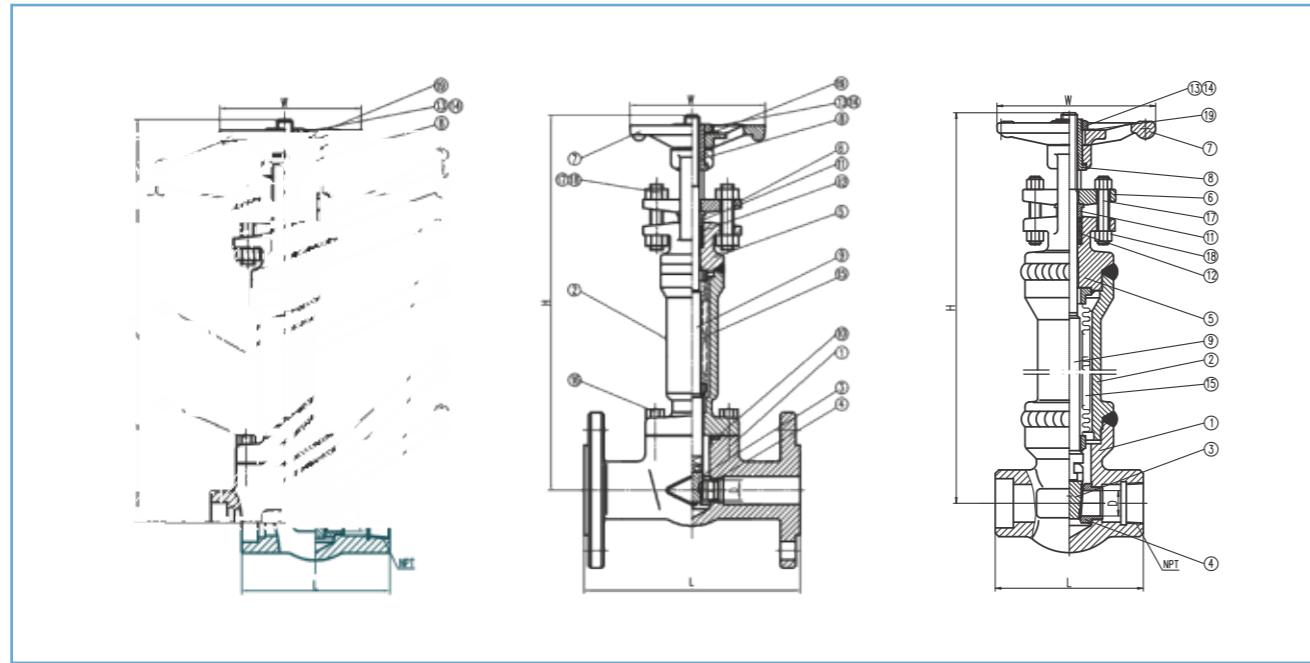

1	ASTM A105N	ASTM A182 F11/F22	ASTM A182-F304/F316
2	ASTM A105N	ASTM A182-F11/F22	ASTM A182-F304/F316
3	ASTM A182-F6a	ASTM A182-F6a	ASTM A182-F304/F316
4	ASTM A276-410/STL.OVERLAY	ASTM A276-410/STL.OVERLAY	ASTM A182
5	ASTM A105N	ASTM A182 F11/F22	ASTM A182 F304/F316
6	ASTM A216 WCB	ASTM A216 WCB	ASTM A351 Cf8
7	DUCTILE IRON	DUCTILE IRON	DUCTILE IRON
8	ASTM A276 420	ASTM A276 420	ASTM A276 420
9	ASTM A182 F6a	ASTM A182 F6a	ASTM A182 F304/F316
10	304SS/	304SS/	304/316SS/
11	ASTM A276 420	ASTM A276 420	ASTM A276 304/316
12			DUCTILE IRON
13			ASTM A276 304
14	ASTM A276 304	ASTM A276 304	ASTM A276 304
15	ASTM A276 316Ti	ASTM A276 316Ti	ASTM A276 316Ti
16	ASTM A193 B7	ASTM A193 B16	ASTM A193 B8
17	ASTM A193 B8	ASTM A193 B8	ASTM A193 B8
18	ASTM A194 8	ASTM A194 8	ASTM A194 8
19	ASTM A276 304	ASTM A276 304	ASTM A276 304

Class 800

-API 602

		1/2		3/4		1		1-1/4		1-1/2		2	
		3/8		1/2		3/4		1		1-1/4		1-1/2	
	L	mm	in	mm	in	mm	in	mm	in	mm	in	mm	in
	D	9.5	0.37	12.7	0.5	17.5	0.69	23.8	0.94	28.6	1.13	36.5	1.44
	H	329.2	12.96	353.7	13.93	425.5	16.75	577.4	22.73	577.4	23.73	712.1	28.04
		289.2	11.39	319.8	12.59	372.7	14.67	533.3	21.00	533.3	21.00	700	27.56
	W	90	3.54	90	3.54	110	4.33	150	5.91	150	5.91	150	5.91
	Kg/Lb	3.5	7.72	4.0	8.82	5.5	12.13	8.5	18.74	8.5	18.74	16	35.27

Class 900/1500

-API 602

		1/2		3/4		1		1-1/4		1-1/2		2	
		3/8		1/2		3/4		1		1-1/4		1-1/2	
	L	mm	in	mm	in	mm	in	mm	in	mm	in	mm	in
	D	9.5	0.37	12.7	0.5	16	0.63	22.5	0.89	27	1.06	35	1.38
	H	300	11.81	320	12.60	380	14.96	530	20.87	530	20.87	580	22.83
	W	90	3.54	110	4.33	150	5.91	150	5.91	150	5.91	180	7.09
	Kg/Lb	5	11.02	7.5	16.53	11.5	25.35	19	41.89	19	41.89	30	66.14

Class 150-300-600

-API 602

-ASME B16.5

-ASME B16.10

		1/2		3/4		1		1-1/2		2		
		mm	in	mm	in	mm	in	mm	in	mm	in	
	Class 150	L	108	4.25	117	4.61	127	5.0	165	6.50	178	7.01
	Class 300	L	140	5.51	152	5.98	165	6.50	190	7.48	216	8.5
	Class 600	L	165	6.50	190	7.48	216	8.50	241	9.49	292	11.50
		D	9.5	0.37	12.7	0.50	17.5	0.69	28.6	1.13	36.5	1.44
		H	145.5	5.73	151.8	5.98	179.7	7.07	247	9.72	268.7	10.58
		W	90	3.54	90	3.54	110	4.33	150	5.91	150	5.91
	Class 150		3	6.61	3.8	8.38	4.8	10.58	10	22.05	15	33.07
	Class 300	Kg/Lb	3.4	7.50	4.5	9.92	5.7	12.57	11.5	25.35	17	37.48
	Class 600		4	8.82	5.2	11.46	6.6	14.55	12.7	28.00	18	39.68

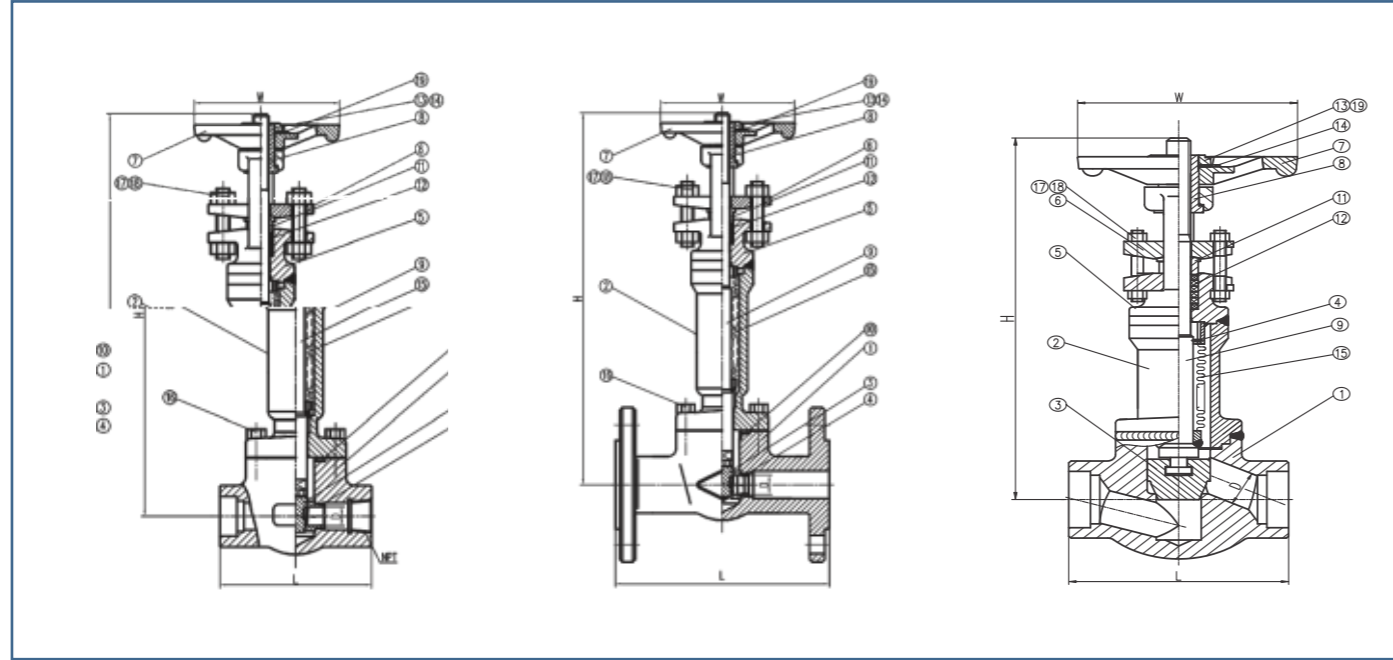

1	ASTMA105NSTL.OVERLAY	ASTMA182	ASTMA182
2	ASTMA105N	ASTMA182-F11/F22	ASTMA182-F304/F316
3	ASTMA182-F6a	ASTMA182-F6a	ASTMA182-F304/F316
4	ASTMA276 304	ASTMA276 304	ASTMA276 304
5	ASTMA105N	ASTMA182 F11/F22	ASTMA182 F304/F316
6	ASTMA216 WCB	ASTMA216 WCB	ASTMA351 CF8
7	DUCTILE IRON	DUCTILE IRON	DUCTILE IRON
8	ASTMA276 420	ASTMA276 420	ASTMA276 420
9	ASTMA182 F6a	ASTMA182 F6a	ASTMA182 F304/F316
10	304SS/	304SS/	304/316SS/
11	ASTMA276 420	ASTMA276 420	ASTMA276 304/316
12			
13			ASTMA276 304
14	ASTMA276 304	ASTMA276 304	ASTMA276 304
15	ASTMA276 316Ti	ASTMA276 316Ti	ASTMA276 316Ti
16	ASTMA193 B7	ASTMA193 B16	ASTMA193 B8
17	ASTMA193 B8	ASTMA193 B8	ASTMA193 B8
18	ASTMA194 8	ASTMA194 8	ASTMA194 8
19	ASTMA276 304	ASTMA276 304	ASTMA276 304

Class 800

-API 602

		1/2		3/4		1		1-1/4		1-1/2		2	
		3/8		1/2		3/4		1		1-1/4		1-1/2	
	L	mm	in	mm	in	mm	in	mm	in	mm	in	mm	in
	D	9.5	0.37	12.7	0.50	17.5	0.50	23	0.91	28.6	1.13	36.5	1.44
	H	356.1	14.02	363.5	14.31	416.3	14.31	506.3	19.93	506.3	19.93	599.2	23.59
		311.7	12.27	353.5	13.92	363.8	13.92	464.8	18.30	452.3	17.81	563.8	22.20
	W	110	4.33	110	4.33	110	4.33	150	5.91	150	5.91	180	7.09
	Kg/Lb	3.5	7.72	4.5	9.92	5.5	9.92	11	24.25	11	24.25	17.5	38.58

Class 900/1500

-API 602

		1/2		3/4		1		1-1/4		1-1/2		2	
		3/8		1/2		3/4		1		1-1/4		1-1/2	
	L	mm	in	mm	in	mm	in	mm	in	mm	in	mm	in
	D	9.0	0.35	12.0	0.47	15.0	0.59	27	1.06	27	1.06	32	1.26
	H	356.7	14.04	434.8	17.12	482.7	19.00	587.8	23.14	587.8	23.14	630	24.80
	W	90	3.54	110	4.33	150	5.91	180	7.09	180	7.09	250	9.84
	Kg/Lb	5.5	12.13	7.5	16.53	11.5	25.35	19	41.89	19	41.89	32	70.55

Class 150-300-600

-API 602

-ASME B16.5

-ASME B16.10

		1/2		3/4		1		1-1/2		2	
		mm	in	mm	in	mm	in	mm	in	mm	in
Class 150	L	108	4.25	117	4.61	127	5.0	165	6.50	203	7.01
Class 300	L	152	5.98	178	7.01	203	7.99	229	9.02	267	8.5
Class 600	L	165	6.50	190	7.48	216	8.50	241	9.49	292	11.50
	D	9.5	0.37	12.7	0.50	17.5	0.69	28.6	1.13	36.5	1.44
	H	356.1	14.02	363.5	14.31	416.3	16.39	506.3	19.93	599.2	10.58
	W	110	4.33	110	4.33	110	4.33	150	5.91	180	5.91
Class 150		5.5	12.13	6.0	13.23	8.5	18.74	14	30.86	21.5	33.07
Class 300	Kg/Lb	6.0	13.23	7.0	15.43	10.5	23.15	17	37.48	25	37.48
Class 600		6.5	14.33	7.5	16.53	11	24.25	18.5	40.79	26.5	39.68

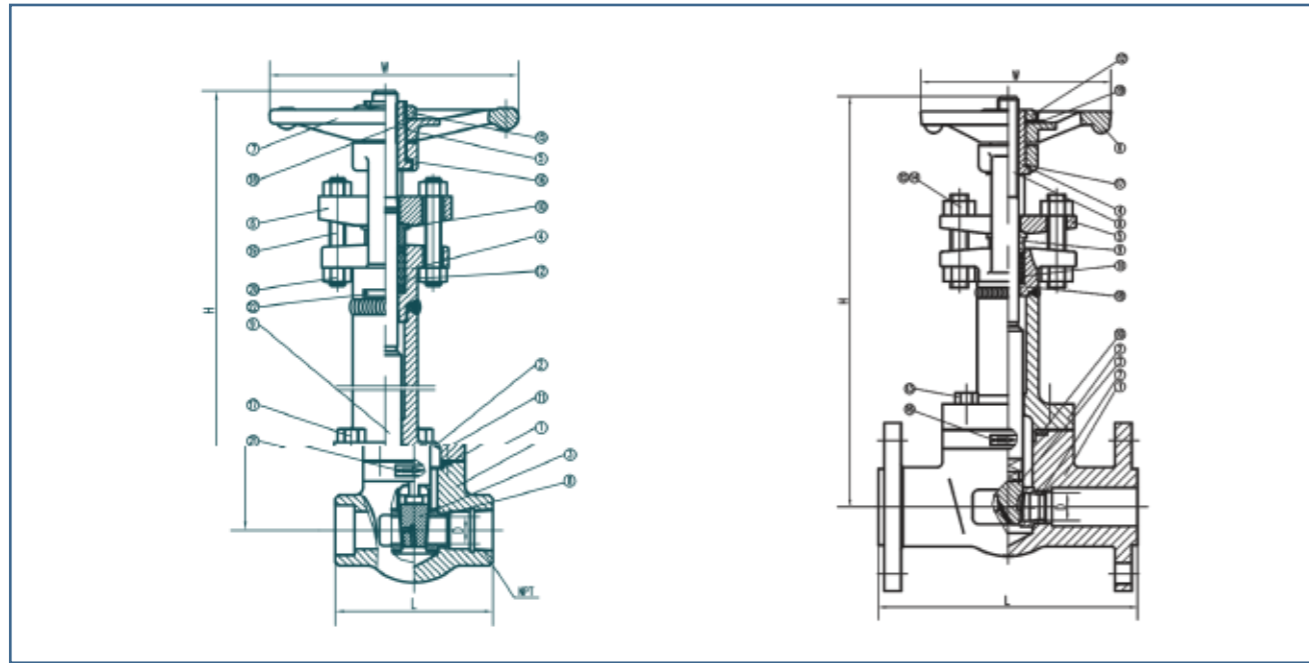

Class 800

-API 602

		1/2		3/4		1		1-1/4		1-1/2		2	
		3/8		1/2		3/4		1		1-1/4		1-1/2	
	L	mm	in	mm	in	mm	in	mm	in	mm	in	mm	in
		76	2.99	86	3.39	102	4.02	118	4.65	118	4.65	132	5.20
	D	9.5	0.37	12.7	0.50	17.5	0.69	23.8	0.94	28.6	1.13	36.5	1.44
	H	403	15.87	428	16.85	470.5	18.52	499.3	19.66	503.4	19.82	549.6	21.64
	W	90	3.54	110	4.33	150	5.91	150	5.91	150	5.91	180	7.09
	Kg/Lb	3	6.61	3.7	8.16	5.3	11.68	8.5	18.74	8.5	18.74	10.8	23.81

1		ASTM A182 F304/ F316
2		ASTM A182 F304/ F316
3		ASTM A182 F304/ F316/ STL.OVERLAY
4		ASTM A182 F304/ F316/ STL.OVERLAY
5		ASTM A182 F304/ F316/ STL.OVERLAY
6		ASTM A351 CF8
7		
8		
9		ASTM A182 F304/F316
10		304SS/SPIRAL WOUND GRAPHITE
11		ASTM A276 304 /316
12		
13		ASTMA276 304
14		ASTMA276 304
15		ASTMA276 304
16		ASTM A320 B8 C12
17		ASTM A193 B8
18		ASTM A194 8
19		ASTMA276 304
20		ASTMA276 304

Class 150-300-600

-API602

-ASME B16.5

-ASME B16.10

		1/2		3/4		1		1-1/2		2	
		mm	in	mm	in	mm	in	mm	in	mm	in
Class 150	L	108	4.25	117	4.61	127	5.0	165	6.50	178	7.01
Class 300	L	140	5.51	152	5.98	165	6.50	190	7.48	216	8.50
Class 600	L	165	6.50	190	7.48	216	8.50	241	9.49	292	11.50
	D	9.5	0.37	12.7	0.50	17.5	0.69	28.6	1.13	36.5	1.44
	H	403	15.87	428	16.85	470.5	18.52	503.4	19.82	549.6	21.64
	W	90	3.54	110	4.33	150	5.91	150	5.91	180	7.09
Class 150		4.5	9.92	5.5	12.13	7	15.43	13	28.66	18.5	40.79
Class 300	Kg/Lb	5	11.02	6.2	13.67	8	17.64	12.5	27.56	20.5	45.19
Class 600		5.6	12.35	7	15.43	9	19.84	15.5	34.17	21.5	47.40

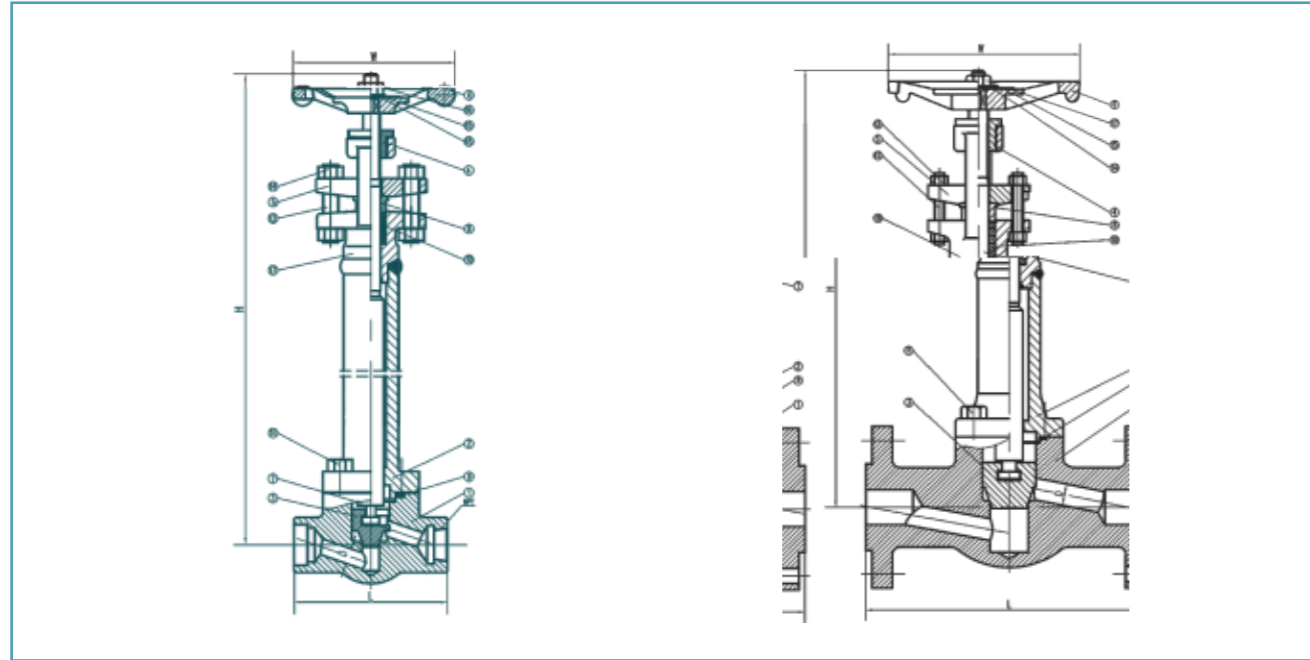

Class 800

-API 602

		1/2		3/4		1		1-1/4		1-1/2		2	
		3/8		1/2		3/4		1		1-1/4		1-1/2	
		mm	in	mm	in	mm	in	mm	in	mm	in	mm	in
	L	76	2.99	86	3.39	102	4.02	140	5.51	140	5.51	170	6.69
	D	9.5	0.37	12.7	0.50	17.5	0.69	23	0.91	28.6	1.13	36.5	1.44
	H	394.3	15.52	16.7	16.41	470.5	18.52	91.8	19.36	537.8	21.17	569.8	22.43
	W	90	3.54	110	4.33	150	5.91	150	5.91	180	7.09	180	7.09
	Kg/Lb	3	6.61	3.5	7.72	6	13.23	9	19.84	10.5	23.15	15.5	34.17

1	ASTM A182 F304 /F316/STL.OVERLAY
2	ASTM A182 F304 /F316
3	ASTM A182 F304/ F316/ STL.OVERLAY
4	
5	ASTM A182 F304/ F316/ STL.OVERLAY
6	ASTM A351 CF8
7	
8	ASTM A276 304/316
9	ASTM A182 F304 /F316
10	304 /316SS /
11	ASTM A320 B8 Cl2
12	DUCTILE IRON
13	ASTMA276 304
14	ASTM A276 304
15	ASTM A193 B8
16	ASTM A194 8
17	ASTM A276 304
18	ISO 3506 A1-50
19	ASTM A276 304

Class 150-300-600

-API602

-ASME B16.5

-ASME B16.10

		1/2		3/4		1		1-1/2		2	
		mm	in	mm	in	mm	in	mm	in	mm	in
Class 150	L	108	4.25	117	4.61	127	5.0	165	6.50	203	7.99
Class 300	L	152	5.98	178	7.01	203	7.99	229	7.48	267	10.51
Class 600	L	165	6.50	190	7.48	216	8.50	241	9.49	292	11.50
	D	9.5	0.37	12.7	0.50	17.5	0.69	28.6	1.13	36.5	1.44
	H	394.3	15.52	416.7	16.41	470.3	18.52	537.8	19.82	569.8	22.43
	W	90	3.54	110	4.33	150	5.91	180	5.91	180	7.09
Class 150		5	11.02	6	13.23	7.5	16.53	15	28.66	20	44.09
Class 300	Kg/Lb	5.6	12.35	7.5	16.53	8.3	18.30	16.5	27.56	22	48.50
Class 600		6.1	13.45	7.8	17.20	9.1	20.06	18	34.17	24	52.91

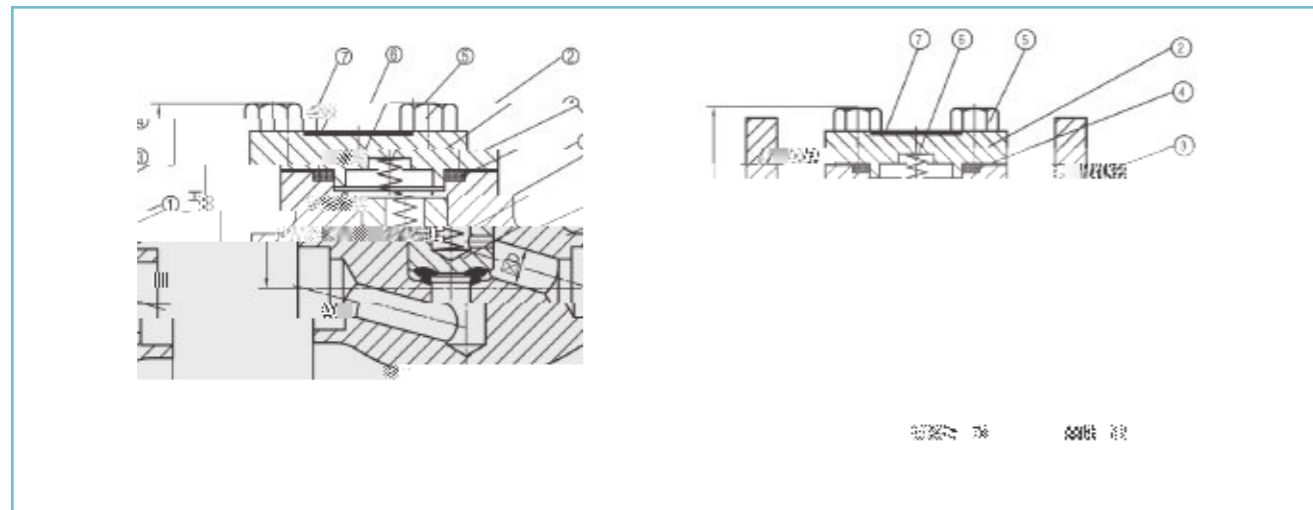

1	ASTM A182 F304 / F316/STL.OVERLAY
2	ASTM A182 F304 / F316
3	ASTM A182 F304/ F316/ STL.OVERLAY
4	
5	ASTM A182 F304/ F316/ STL.OVERLAY
6	ASTM A351 CF8
7	DUCTILE IRON

Class 800

-API 602

		1/2		3/4		1		1-1/4		1-1/2		2	
		3/8		1/2		3/4		1		1-1/4		1-1/2	
	L	mm	in	mm	in	mm	in	mm	in	mm	in	mm	in
	D	76	2.99	86	3.39	102	4.02	140	5.51	140	5.51	170	6.69
	H	9.5	0.37	12.7	0.50	17.5	0.69	23	0.91	28.6	1.13	36.5	1.44
	H	48	1.89	53	2.09	64	2.52	80	3.15	80	3.15	100	3.94
	Kg/Lb	1	2.20	1.5	3.31	2	4.41	4.5	9.92	6	13.23	7.5	16.53

Class 150-300-600

-API602

-ASME B16.5

-ASME B16.10

		1/2		3/4		1		1-1/2		2	
		mm	in	mm	in	mm	in	mm	in	mm	in
Class 150	L	108	4.25	117	4.61	127	5.0	165	6.50	203	7.99
Class 300	L	152	5.98	178	7.01	203	7.99	229	9.02	267	10.51
Class 600	L	165	6.50	190	7.48	216	8.50	241	9.49	292	11.50
	D	9.5	0.37	12.7	0.50	17.5	0.69	28.6	1.13	36.5	1.44
	H	50	1.97	54	2.13	68	2.68	78	3.07	96	3.78
Class 150	Kg/Lb	2.5	5.51	3.3	7.28	4.3	9.48	9	19.84	13	28.66
Class 300	Kg/Lb	3	6.61	3.8	8.38	5.2	11.46	10.5	23.15	15	33.07
Class 600	Kg/Lb	3.5	7.72	4.5	9.92	6	13.23	12	26.46	17	37.48

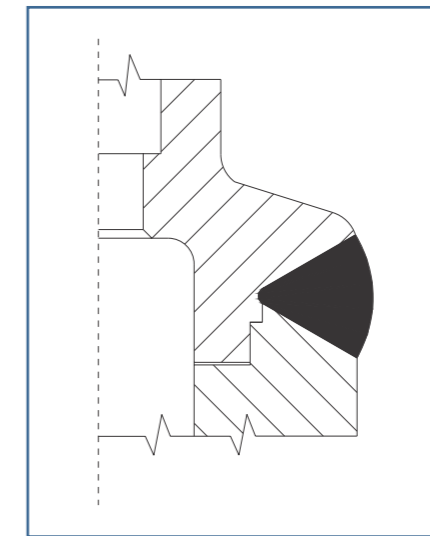

1

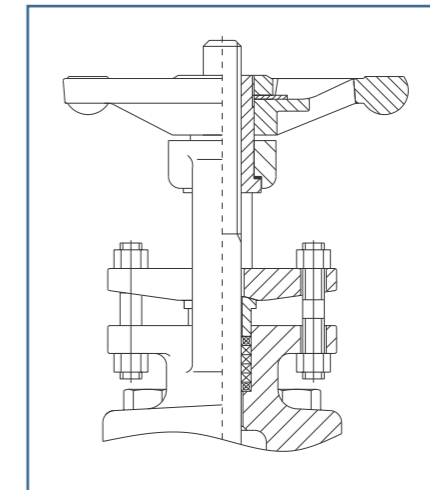

2

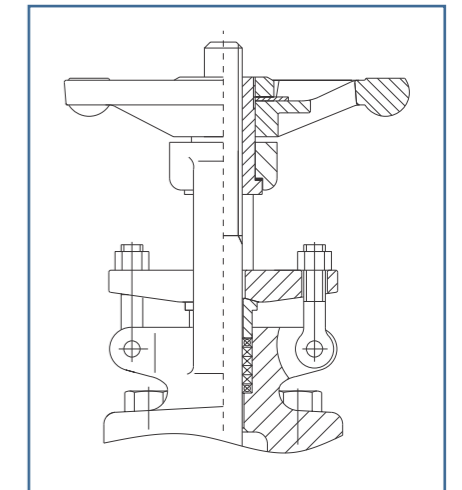

3

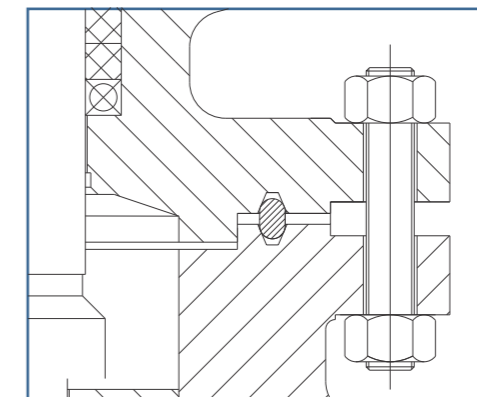

4

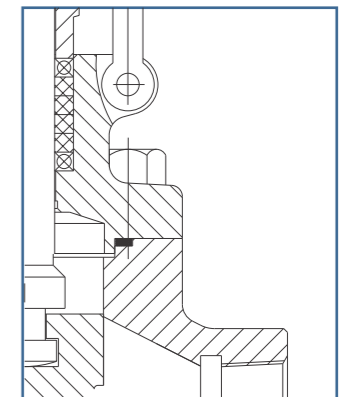

5

3 2

RTJ 1500 2500 5

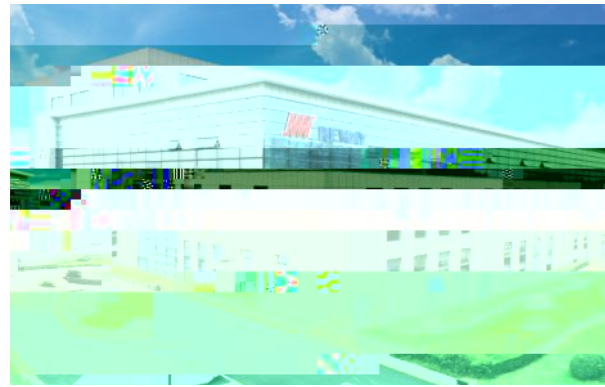

成立于2014年

2,295



230,000
140,061

2006
2013



2008
2015

112,500
98,000



2008

40,000
20,000



2017

3,000
30,000



2020

30,000
19,000 ()
7,000 ()



18

12

()